



education

Department:
Education
PROVINCE OF KWAZULU-NATAL

**NATIONAL
SENIOR CERTIFICATE**

GRADE 11

PHYSICAL SCIENCES P1

COMMON TEST

SEPTEMBER 2019

TIME: 3 hours

MARKS: 150

This question paper consists of 17 pages and 2 data sheets.

INSTRUCTIONS AND INFORMATION TO CANDIDATES

1. Write your name on the **ANSWER BOOK**.
2. This question paper consists of ELEVEN questions. Answer ALL the questions in the ANSWER BOOK.
3. Start EACH question on a NEW page in the ANSWER BOOK.
4. Number the answers correctly according to the numbering system used in this question paper.
5. Leave ONE line between two subsections, for example between QUESTION 2.1 and QUESTION 2.2.
6. You may use a non-programmable calculator.
7. You may use appropriate mathematical instruments.
8. You are advised to use the attached DATA SHEET.
9. Show ALL formulae and substitutions in ALL calculations.
10. Round off your final numerical answers to a minimum of TWO decimal places.
11. Give brief motivations, discussions, et cetera where required.

QUESTION 1 : MULTIPLE CHOICE QUESTIONS

Four options are provided as possible answers to the following questions. Each question has only ONE correct answer. Write only the letter (A - D) next to the question number (1.1 - 1.10) in your ANSWER BOOK, for example 1.11 D.

1.1 Which ONE of the physical quantities has BOTH magnitude and direction?

- A Mass
- B Distance
- C Time
- D Acceleration

(2)

1.2 In the diagram below, an object of mass m is held at rest by a string passing over a frictionless pulley. The mass of the string is negligible.

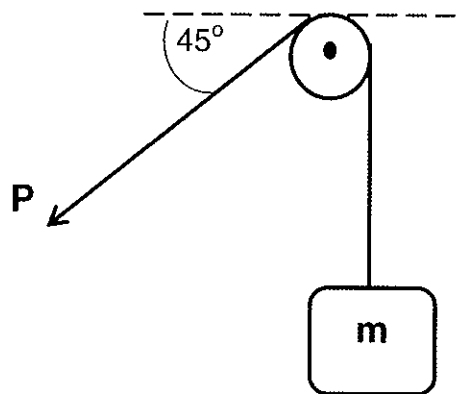

The magnitude of force P in the string is....

- A mg
- B $mg \sin 45^\circ$
- C $\frac{1}{2} mg$
- D $mg \tan 45^\circ$

(2)

- 1.3 The velocity-time graph below shows the motion of a car moving along a straight horizontal path. A constant frictional force acts on the car as it moves.

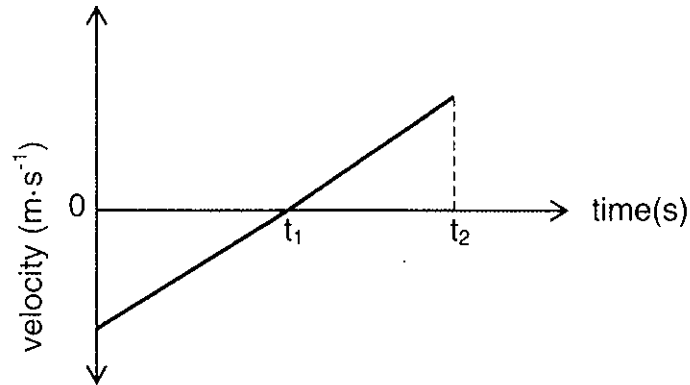

Which ONE of the following statements BEST describes the magnitude of the force exerted by the car's engine from $t = 0$ to $t = t_2$ seconds?

- A It remains constant.
- B It increases and then remains constant.
- C It decreases and then increases.
- D It remains constant and increases. (2)

- 1.4 Two trolleys **A** and **B** of mass m and $2m$ respectively are positioned as shown with a compressed spring between them.

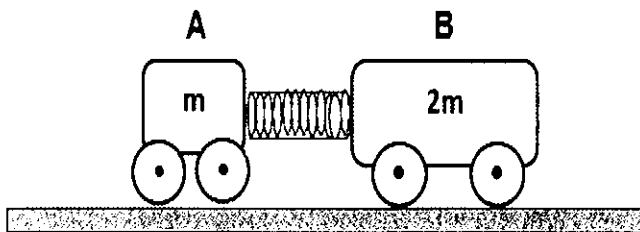

If the force exerted by the spring on trolley A is F , then the force exerted by the spring on trolley B is....

- A $\frac{1}{2}F$
- B F
- C $2F$
- D $4F$ (2)

- 1.5 A box of mass m is at rest on a rough horizontal surface. A force F of constant magnitude is then applied on the box at an angle of 65° to the horizontal, as shown.

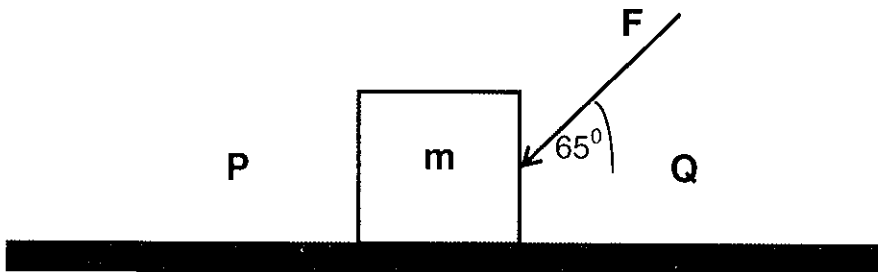

If the box has a uniform horizontal acceleration of magnitude a , then the frictional force acting on the box is ...

- A $F \cos 65^\circ - ma$, in the direction of P.
 - B $F \cos 65^\circ - ma$, in the direction of Q.
 - C $F \sin 65^\circ - ma$, in the direction of P.
 - D $F \sin 65^\circ - ma$, in the direction of Q. (2)
- 1.6 Which of the following graphs best represents the relationship between the magnitude of the gravitational force and the distance between the centres of two objects of significant mass?

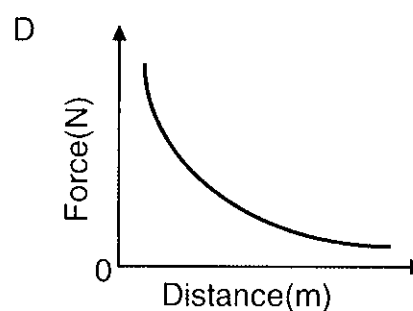
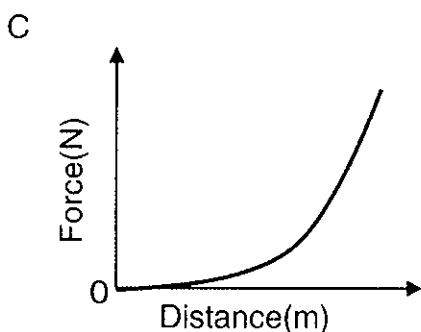
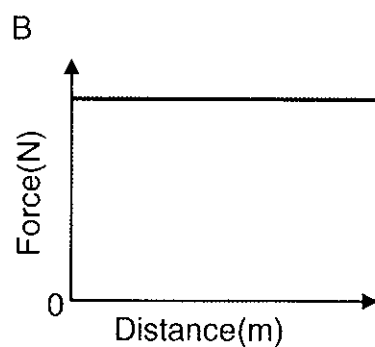
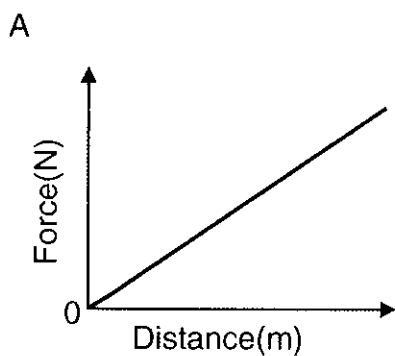

1.7 A straight glass rod placed in a glass of water appears to be bent when viewed from above as shown in the diagram.

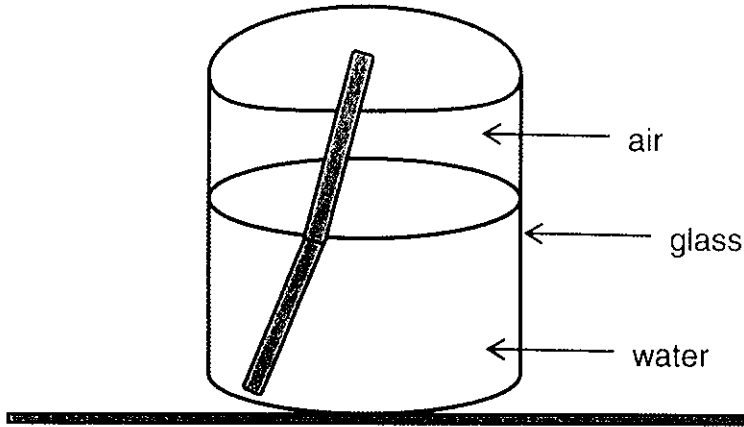

Which ONE of the following statements best explains this observation?

- A Light is reflected as it travels from air to water.
 - B Light is reflected as it travels from water to air.
 - C Light is refracted as it travels from water to air.
 - D Light is refracted as it travels from air to water.
- (2)

1.8 Which diagram correctly represents the electric field pattern in the region between two charged objects?

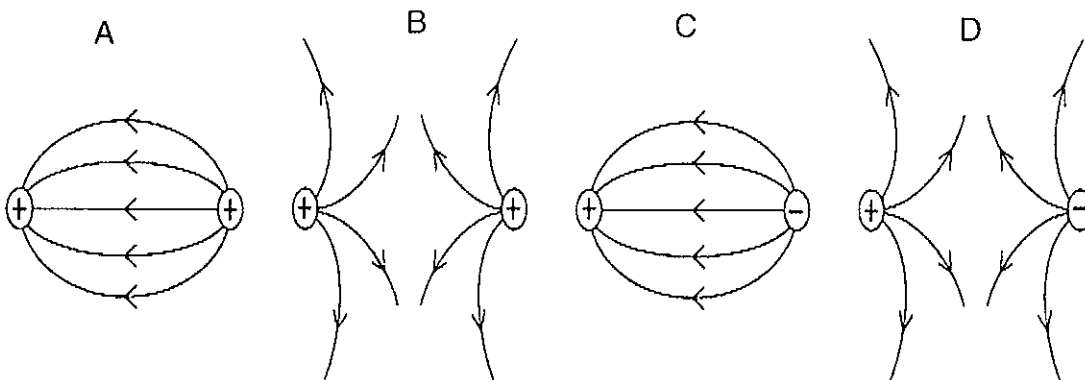

(2)

1.9 When two resistors, each of resistance R , are connected in parallel the effective resistance is Y . When these 2 resistors are connected in series, the total resistance will be:

- A $2 Y$
- B $2 RY$
- C $4 Y$
- D $\frac{1}{2} Y$

(2)

1.10 In the circuit diagram below the resistors are identical and the battery has negligible internal resistance.

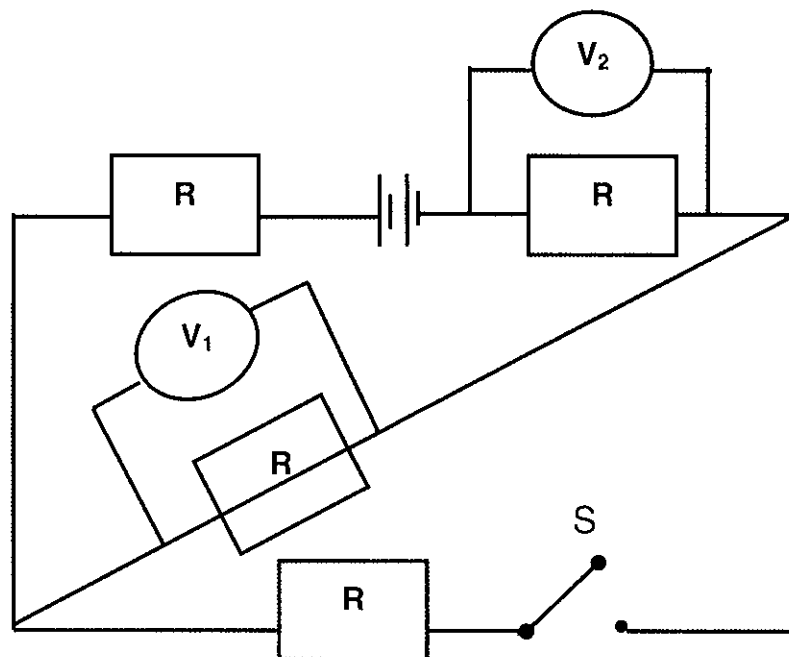

When the switch S is closed, the readings on voltmeters V_1 and V_2 will CHANGE as follows:

	Reading on V_1	Reading on V_2
A	Decreases	Increases
B	Increases	Increases
C	Stays the same	Decreases
D	Increases	Decreases

(2)

[20]

QUESTION 2

The diagram below shows an object P suspended from a ceiling with the aid of three light strings X, Y and Z connected at point O.

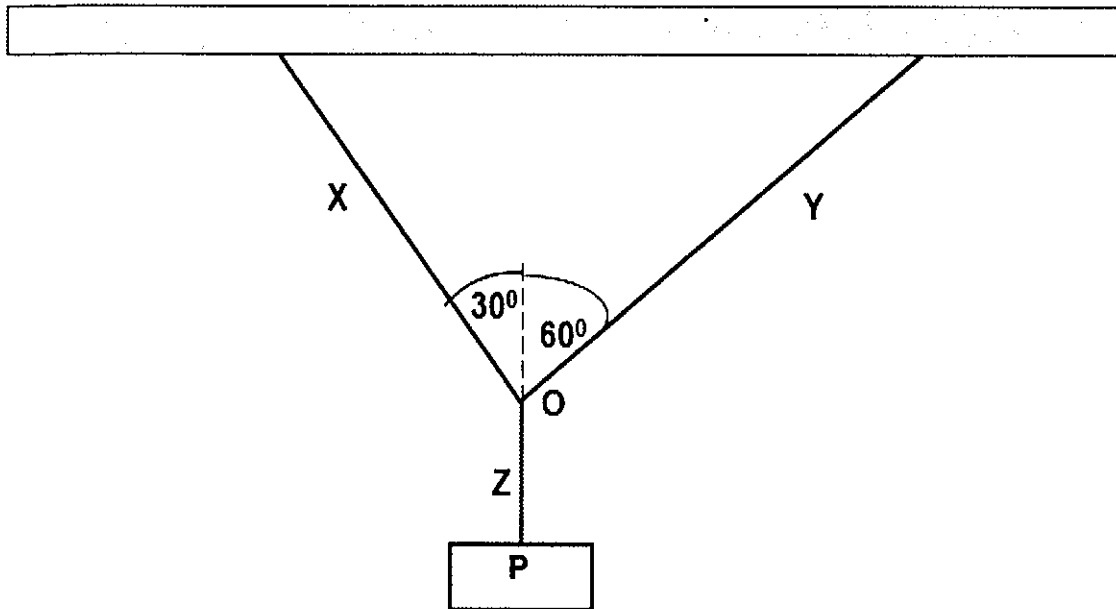

- 2.1 Define the term *resultant vector*. (2)
- 2.2 Draw a closed vector diagram to show all the forces acting at point O. Indicate two angles in your diagram. (4)
- 2.3 Using the vector diagram in **QUESTION 2.2**, identify the string that exerts the largest force on point O. Give a reason for the answer. (2)

The mass of object P is 0,25 kg.

- 2.4 Calculate the magnitude of force X **and** force Y. (4)

[12]

QUESTION 3

Two blocks A and B, lying on a rough horizontal surface, are in contact with each other. When a horizontal force F is applied to block A, the blocks move at a **constant velocity** of $5 \text{ m}\cdot\text{s}^{-1}$ to the right.

The masses of the blocks A and B are $4,0 \text{ kg}$ and $2,5 \text{ kg}$ respectively.
The co-efficient of kinetic friction between each block and the surface is $0,03$.

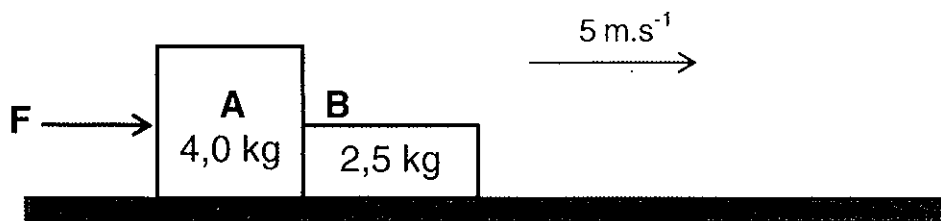

3.1 Calculate the magnitude of the kinetic frictional force acting on:

3.1.1 Block A (3)

3.1.2 Block B (1)

3.2 Write down the magnitude of force F . (1)

A retarding force (a force acting opposite to the direction of motion) of magnitude $4,5 \text{ N}$ is applied horizontally to block B, to slow down the motion of the blocks.

3.3 Draw a labelled free-body diagram indicating all the HORIZONTAL forces acting on block B. (3)

3.4 Calculate the magnitude of the acceleration of block A. (5)

[13]

QUESTION 4

4.1 State Newton's Law of Universal Gravitation in words. (2)

4.2 A man weighs 800 N on the Earth's surface. How far above the Earth's surface will his weight reduce to a quarter of his weight on the Earth's surface? (6)

[8]

QUESTION FIVE

A ray of light is travels from glass to air. **The sketch below shows the refracted ray only.**

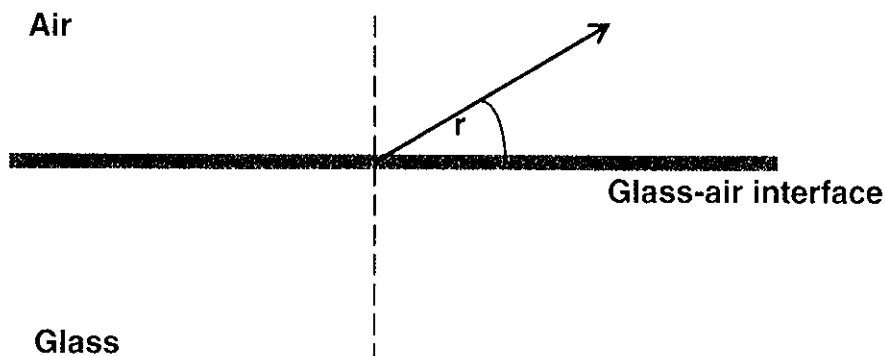

Given: refractive index of glass = 1.5
refractive index of air = 1

- 5.1 Define *refraction of light*. (2)
- 5.2 Draw the above diagram in your answer booklet, and complete the diagram by drawing and labeling the incident ray. Indicate the angle of incidence. (2)
- 5.3 State Snell's law. (2)
- 5.4 If the angle of incidence is 35° , calculate:
- 5.4.1 The angle of refraction. (4)
- 5.4.2 The speed of light in glass. (3)
- 5.5 The angle of incidence is now increased to 45° .
- 5.5.1 Define *critical angle*. (2)
- 5.5.2 Using relevant calculations, determine whether total internal reflection will take place. (5)

[20]

QUESTION SIX

The experimental set up below shows monochromatic light of different colours being passed through a single slit of width 0,30 mm.

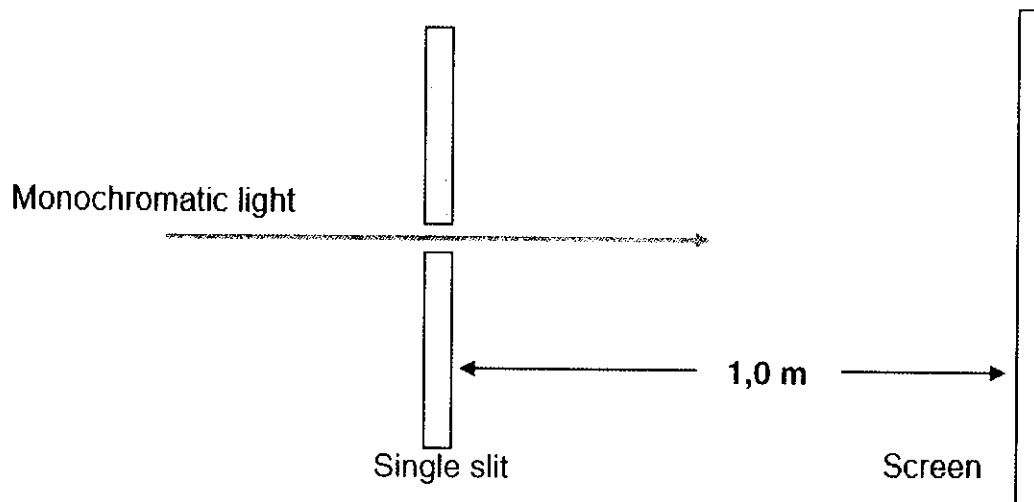

- 6.1 Define *monochromatic light*. (1)
- 6.2 Draw and label the pattern that would be formed on the screen when red light is used. (2)
- 6.3 The following results are obtained.

COLOUR OF LIGHT	WAVELENGTH(nm)	POSITION OF FIRST DARK LINE FROM THE CENTRE (mm)
Red	620	2,07
Green	570	1,90
Blue	495	1,65

For this experiment, write down:

- 6.3.1 The dependent variable (1)
- 6.3.2 The independent variable (1)
- 6.3.3 ONE controlled variable (1)
- 6.3.4 A conclusion for this experiment (2)

[8]

QUESTION 7

Two identical, small charged spheres, A and B, on isolated stands are placed a distance x metres apart as indicated in the diagram. The charge on sphere A is -5×10^{-6} C while the magnitude of the charge on sphere B is UNKNOWN.

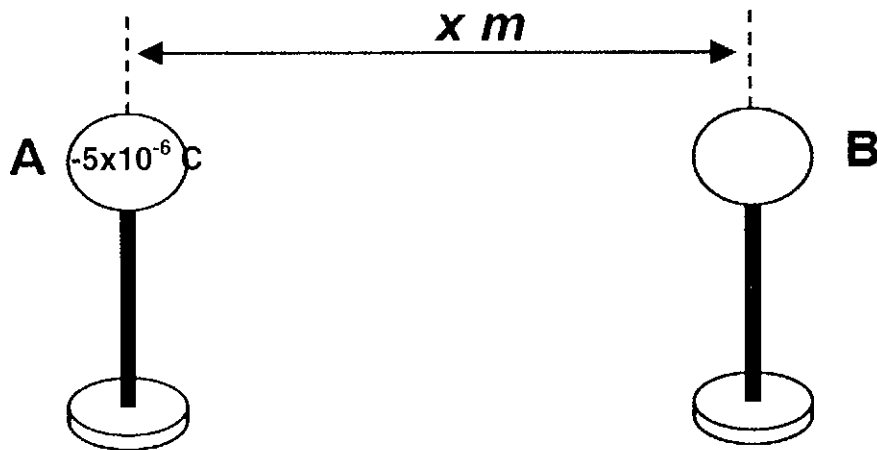

7.1 The following diagram illustrates the electric field pattern around sphere B.

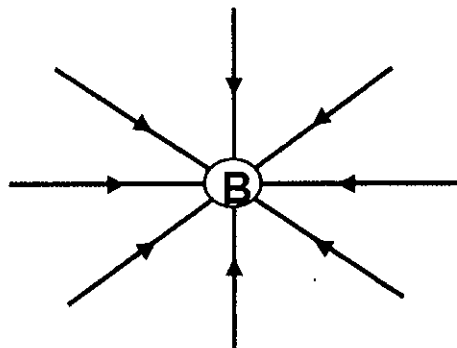

Is sphere B **positively** or **negatively** charged? Give a reason. (2)

7.2 The charged spheres A and B are allowed to touch and are then moved back to their original positions x metres apart. The charge on each sphere after contact is -3×10^{-6} C.

7.2.1 Calculate the ORIGINAL charge on sphere B (i.e. before it made contact with sphere A). (4)

7.2.2 Which of the spheres (**A** or **B**) LOST electrons upon contact? Give a reason for the answer. (2)

[8]

QUESTION EIGHT

Two point charges of magnitude $+5 \mu\text{C}$ and $+8 \mu\text{C}$ are placed a distance of $0,25 \text{ m}$ apart.

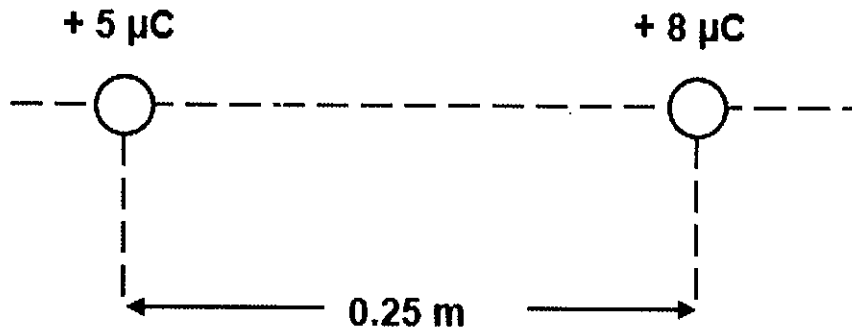

- 8.1 Use Coulomb's Law to calculate the magnitude of the force of repulsion that the charges exert on each other. (4)

R is a point on the line joining the two charges, a distance of X metres from the $+8 \mu\text{C}$ charge, such that the NET electric field at point R is ZERO.

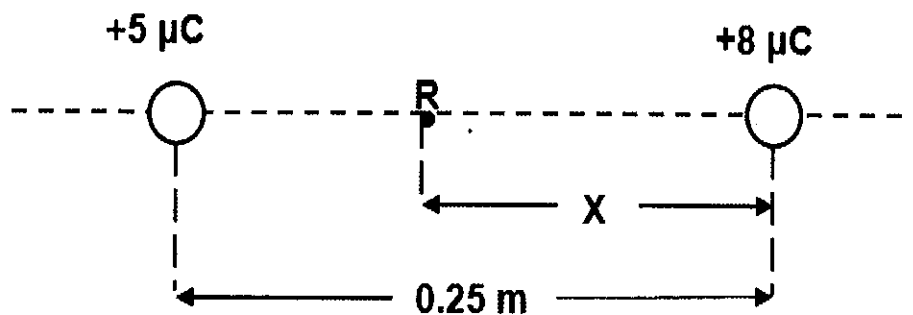

- 8.2 Define *electric field at a point*. (2)
- 8.3 Show that the distance X is equal to $0,14 \text{ m}$. (6)

[12]

QUESTION NINE

9.1 State Faraday's Law of Electromagnetic Induction in words. (2)

9.2 A bar magnet is dropped vertically downwards through a circular conducting loop, as shown below. An emf is induced in the coil.

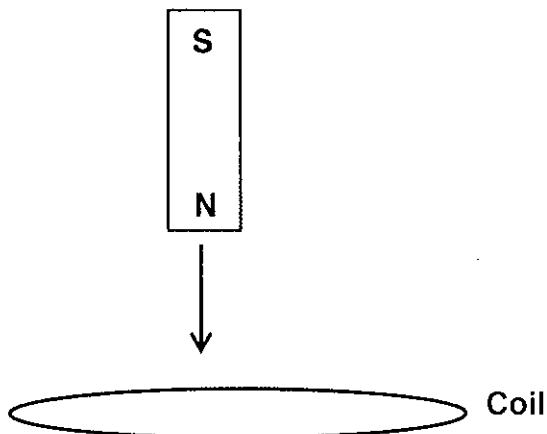

The direction of the induced current is viewed from above.

- 9.2.1 State the direction of the induced current. Choose from **clockwise** or **anticlockwise**. (2)
- 9.2.2 Explain why an emf is induced across the ends of the coil. (2)
- 9.3 A flat coil of wire has an area of $0,020 \text{ m}^2$ and consists of 50 turns. At $t = 0 \text{ s}$, the coil is oriented so that the normal to its surface makes an angle of 0° to a constant magnetic field of magnitude $0,18 \text{ T}$. The coil is then rotated in a time of $0,10$ seconds along its axis so that the normal to the surface makes an angle of 60° to the magnetic field. Calculate the average induced emf in the coil. (5)
- 9.4 Explain the meaning of the minus sign in the equation for Faraday's law of electromagnetic induction.

$$\epsilon = - \frac{N\Delta\phi}{\Delta t}$$

(2)

[13]

QUESTION 10

Two grade11 learners conduct two separate experiments (**experiment A** and **experiment B**) to verify the relationship between the potential difference across a resistor and the current through the resistor. They each used the following components to set up their circuits: a battery, an ammeter, a resistor of unknown resistance, a voltmeter, a switch, conducting wire and a rheostat.

The Current vs Potential Difference graphs obtained by each learner is shown below. Both graphs pass through the origin.

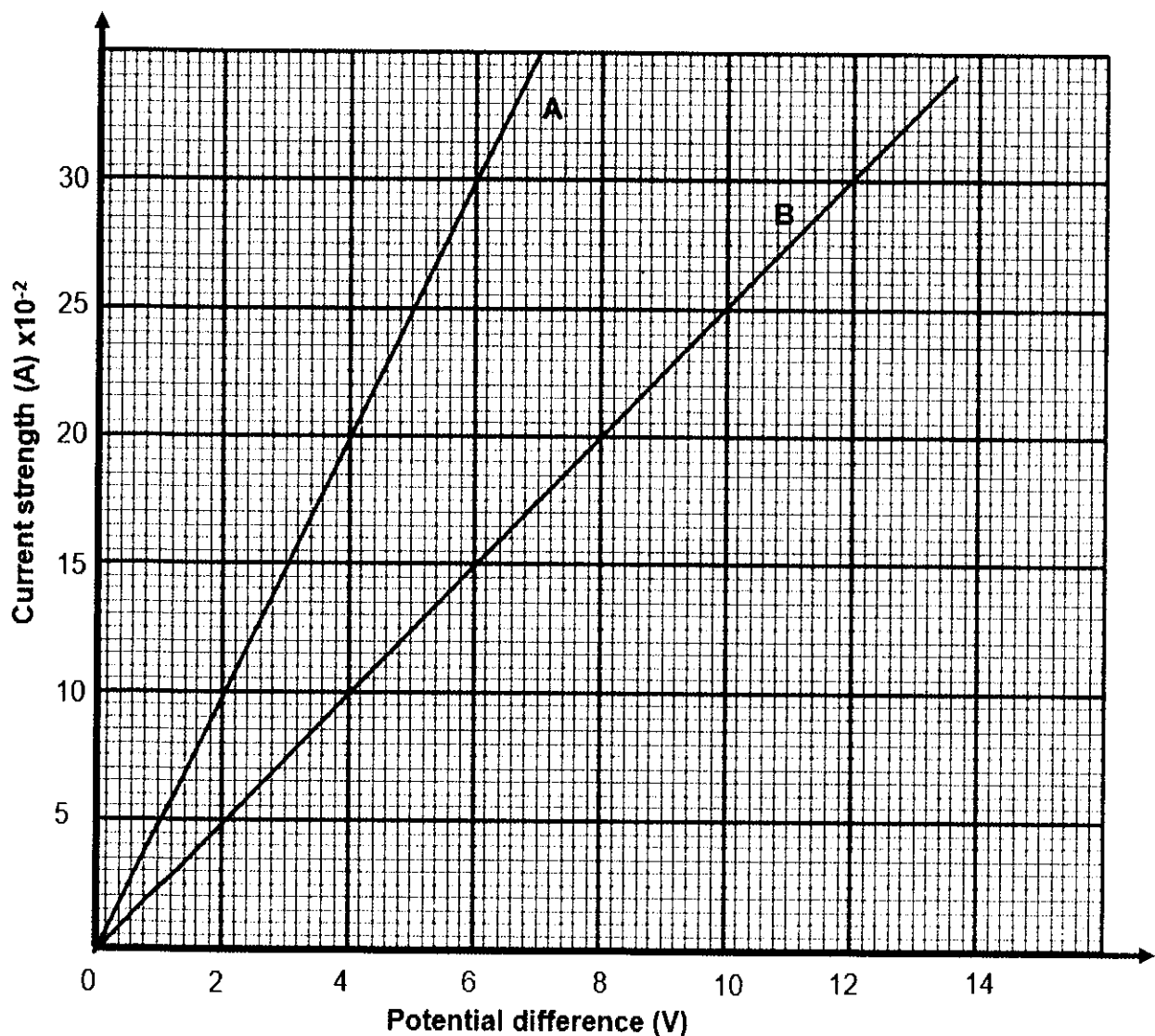

10.1 Write down the name of the law that is being investigated in these experiments. (1)

- 10.2 What is the function of the rheostat? (2)
- 10.3 State ONE precaution that the learners would have to take to ensure that the temperature of their resistors remains constant. (1)
- 10.4 Draw a circuit diagram to show how the learners should connect the given components in the circuit. (4)
- 10.5 **Consider graph B.**
- 10.5.1 What is the relationship between the current and potential difference across the resistor? (1)
- 10.5.2 What does the gradient of the graph represent? (1)
- 10.5.3 What is the current through the resistor when the potential difference across the resistor is 6 V? (1)
- 10.5.4 Using the graph, calculate the resistance of the resistor in experiment B. (4)
- 10.6 **Consider graphs A and B.**
- 10.6.1 Which experiment used a resistor with higher resistance? Choose from **A** or **B**. (1)
- 10.6.2 Give a reason for the answer. (2)

[18]

QUESTION 11

11.1 In the circuit below, the battery has an EMF of 12 V. The battery and the connecting wires have negligible resistance.

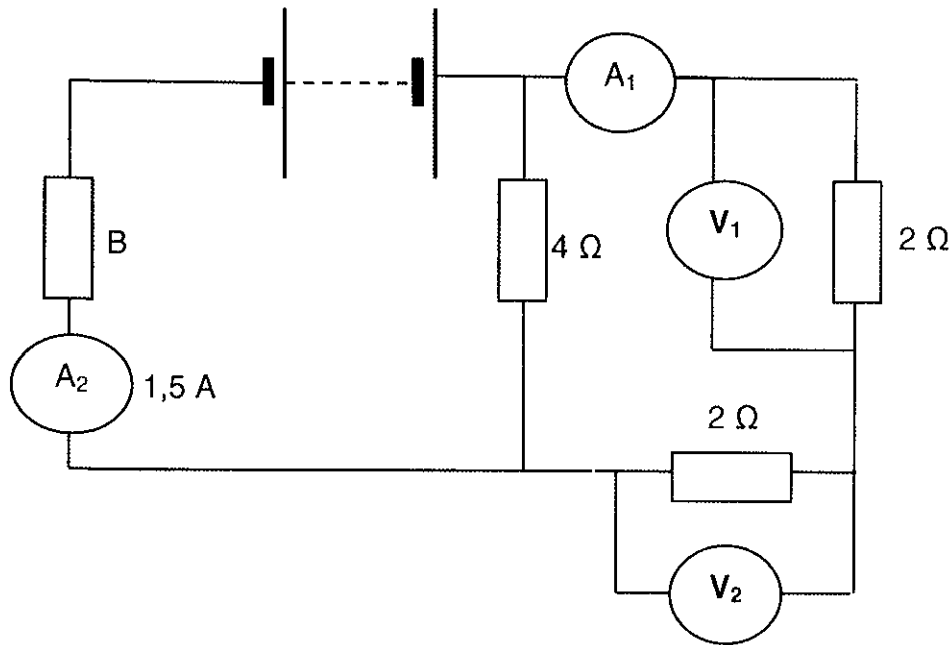

Ammeter A_2 reads 1,5 A

- 11.1 Calculate the total resistance in the circuit. (3)
- 11.2 Determine the reading on ammeter A_1 . (2)
- 11.3 Calculate the reading on voltmeter V_1 . (3)
- 11.4 Calculate the resistance of resistor B. (5)
- 11.5 Determine the energy transferred to resistor B in 10 minutes. (4)
- 11.6 How does the reading on V_1 compare to that on V_2 ?
Choose from GREATER THAN, LESS THAN or EQUAL TO. (1))

[18]

TOTAL: 150

**DATA FOR PHYSICAL SCIENCES GRADE 11
PAPER 1 (PHYSICS)**

TABLE 1: PHYSICAL CONSTANTS

NAME	SYMBOL	VALUE
Acceleration due to gravity	G	9,8 m·s ⁻²
Gravitational constant	G	6,67 x 10 ⁻¹¹ N·m ² ·kg ⁻²
Coulomb's constant	K	9,0 x 10 ⁹ N·m ² ·C ⁻²
Speed of light in a vacuum	C	3,0 x 10 ⁸ m·s ⁻¹
Charge on electron	e	-1,6 x 10 ⁻¹⁹ C
Electron mass	m _e	9,11 x 10 ⁻³¹ kg
Radius of earth	R _E	6,38 x 10 ⁶ m
Mass of earth	M _E	5,98 x 10 ²⁴ kg

TABLE 2: FORMULAE**MOTION**

$v_f = v_i + a \Delta t$	$\Delta x = v_i \Delta t + \frac{1}{2} a \Delta t^2$
$v_f^2 = v_i^2 + 2a \Delta x$	$\Delta x = \left(\frac{v_f + v_i}{2} \right) \Delta t$

FORCE

$F_{net} = ma$	$w = mg$
$F = \frac{Gm_1m_2}{r^2}$	$f_{s(max)} = \mu_s N$
$f_k = \mu_k N$	

WAVES, SOUND AND LIGHT

$v = f \lambda$	$T = \frac{1}{f}$
$n_i \sin \theta_i = n_r \sin \theta_r$	$n = \frac{c}{v}$

ELECTROSTATICS

$F = \frac{kQ_1Q_2}{r^2}$	$(k = 9,0 \times 10^9 \text{ N}\cdot\text{m}^2\cdot\text{C}^{-2})$	$E = \frac{F}{q}$
$E = \frac{kQ}{r^2}$	$(k = 9,0 \times 10^9 \text{ N}\cdot\text{m}^2\cdot\text{C}^{-2})$	$V = \frac{W}{Q}$

ELECTROMAGNETISM

$\varepsilon = -N \frac{\Delta\Phi}{\Delta t}$	$\Phi = BA \cos \theta$
--	-------------------------

CURRENT ELECTRICITY

$I = \frac{Q}{\Delta t}$	$R = \frac{V}{I}$
$\frac{1}{R} = \frac{1}{r_1} + \frac{1}{r_2} + \frac{1}{r_3} + \dots$	$R = r_1 + r_2 + r_3 + \dots$
$W = Vq$	$P = \frac{W}{\Delta t}$
$W = VI \Delta t$	$P = VI$
$W = I^2R \Delta t$	$P = I^2R$
$W = \frac{V^2 \Delta t}{R}$	$P = \frac{V^2}{R}$



education

Department:
Education
PROVINCE OF KWAZULU-NATAL

PHYSICAL SCIENCES P1

COMMON TEST

SEPTEMBER 2019

MARKING GUIDELINE

**NATIONAL
SENIOR CERTIFICATE**

GRADE 11

This marking guideline consists of 12 pages.

QUESTION ONE

1.1 D ✓✓

1.2 A ✓✓

1.3 A ✓✓

1.4 B ✓✓

1.5 B ✓✓

1.6 D ✓✓

1.7 C ✓✓

1.8 B ✓✓

1.9 C ✓✓

1.10 A ✓✓

[20]

QUESTION TWO

2.1 The sum of two or more vectors acting on an object. ✓✓ OR (2)
 That single vector which has the same effect as all the other vectors acting together. ✓✓

2.2

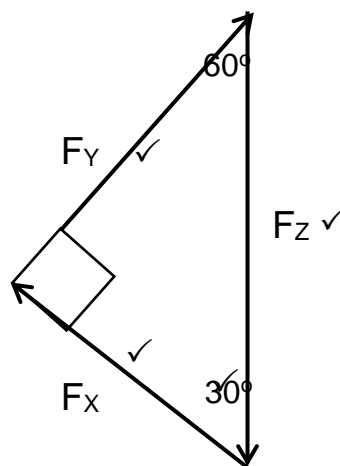
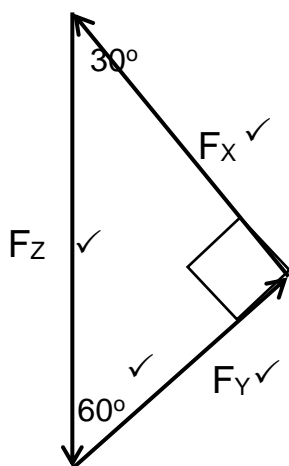

F_x - Force in string X
 F_y - Force in string Y
 F_z - Force in string Z / Weight

Marking Rubric : Diagram	
Criteria	Mark allocation
Forces F_x , F_y and $F_z(W)$ correctly drawn and labelled in a closed triangle.	3 x 1 = 3
Any two angles shown correctly	1
If no arrows shown, penalise once (max $\frac{3}{4}$)	

(2)

(4)

2.3 **POSITIVE MARKING FROM QUESTION 2.2**

Z / F_z . ✓ The lengths of the sides of a triangle represent the magnitude of the forces. Z is (the largest force) opposite the largest angle ✓ in the vector diagram.

OR Z is the hypotenuse ✓ (of the triangle)/ it represents the weight

2.4 $F_z = W = m \cdot g = 0,25 \times 9,8 = 2,45 \text{ N}$ ✓

$$\sin 60^\circ = \frac{F_x}{F_z} \quad \checkmark \quad \text{OR} \quad \cos 30^\circ = \frac{F_x}{F_z}$$

$$\cos 30^\circ = \frac{F_x}{2,45}$$

$$\sin 60^\circ = \frac{F_x}{2,45} \quad \checkmark$$

$$F_x = 2,122 \text{ N} \quad \checkmark \quad F_x = 2,122 \text{ N} \quad \checkmark$$

$$\cos 60^\circ = \frac{F_y}{F_z} \quad \text{OR} \quad \sin 30^\circ = \frac{F_y}{F_z}$$

$$\cos 60^\circ = \frac{F_y}{2,45} \quad \sin 30^\circ = \frac{F_y}{2,45} \quad (4)$$

$$F_y = 1,225 \text{ N} \quad \checkmark \quad F_y = 1,225 \text{ N} \quad \checkmark$$

CRITERIA:

- Correctly calculating F_z / W . ✓
- Any correct formula involving a trigonometric ratio. ✓
- F_x correctly computed. ✓
- F_y correctly computed. ✓

[12]

QUESTION THREE

3.1.1 $f_k = \mu_k F_N \checkmark$
 $= 0,03 \times (4 \times 9,8) \checkmark$
 $= 1,176 \text{ N} \checkmark$ (3)

3.1.2 $f_k = \mu_k F_N$
 $= 0,03 \times (2,5 \times 9,8)$
 $= 0,735 \text{ N} \checkmark$ (1)

3.2 **Positive marking from QUESTION 3.1**
 $F = 1,176 + 0,735 = 1,911 \text{ N} \checkmark$ (1)

3.3

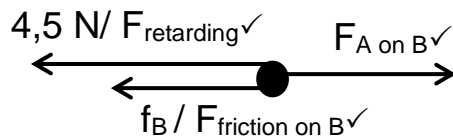

- 1 mark for each force correctly drawn and labelled.
 - Any additional force: deduct 1 mark (maximum 2/3)
- (3)

3.4 $F_{NET} = ma \checkmark$
 $F_{NET \text{ on } B} = 4,5 + 0,735 - F_{A \text{ on } B} = 2,5a \checkmark$
 $F_{NET \text{ on } A} = -1,911 + 1,176 + F_{B \text{ on } A} \checkmark = 4a \checkmark$
 $a = 0,69 \text{ m} \cdot \text{s}^{-2} \checkmark$ (if masses are added then 3/5 max)

(5)

[13]

QUESTION FOUR

- 4.1 Every body in the universe attracts every other body with a gravitational force that is directly proportional to the product of their masses ✓ and inversely proportional to the square of the distance between their centres. ✓ (2)

- 4.2 Let the height above the Earth's surface be "h"
Let R be the distance from the centre to h

$$F_{g_{\text{Earth}}} = 800 \text{ N} , F_{g_h} = 200 \text{ N}$$

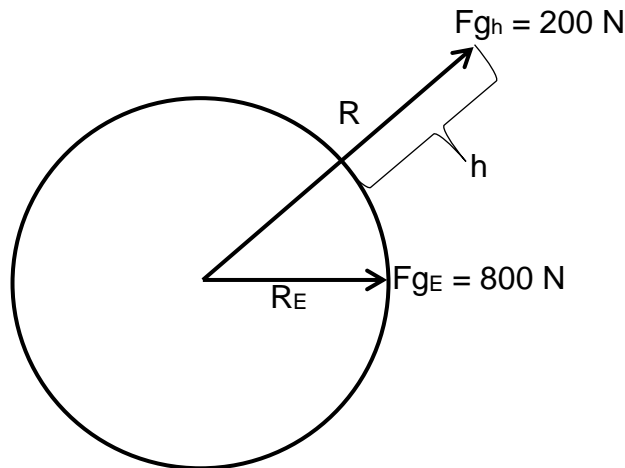

$$F_{g_E} = 4 F_{g_h} \checkmark$$

$$\frac{GmM_E}{R_E^2} \checkmark = 4 \frac{GmM_E}{(R_E+h)^2} \checkmark$$

$$\frac{1}{R_E^2} = \frac{4}{(R_E+h)^2}$$

$$h = R_E \checkmark = 6,38 \times 10^6 \text{ m} \checkmark$$

Let R be the distance from the centre to h

OR $F_g = m \cdot g$

$$800 = m \cdot 9,8$$

$$= 81,633 \text{ kg} \checkmark$$

$$\frac{F = G \cdot m \cdot M_E}{R^2} \checkmark$$

$$\frac{200 \checkmark = 6,67 \times 10^{-11} \cdot 5,98 \times 10^{24} \cdot 81,633 \checkmark}{R^2}$$

$$R = 1,276 \times 10^7 \text{ m}$$

$$h = R - R_E$$

$$= 1,276 \times 10^7 - 6,38 \times 10^6 \checkmark$$

$$= 6,38 \times 10^6 \text{ m} \checkmark$$

(6)

[8]

QUESTION FIVE

5.1 It is the change in direction/bending of light as it passes from one medium to another of different optical density. ✓✓ (2 or 0). (2)

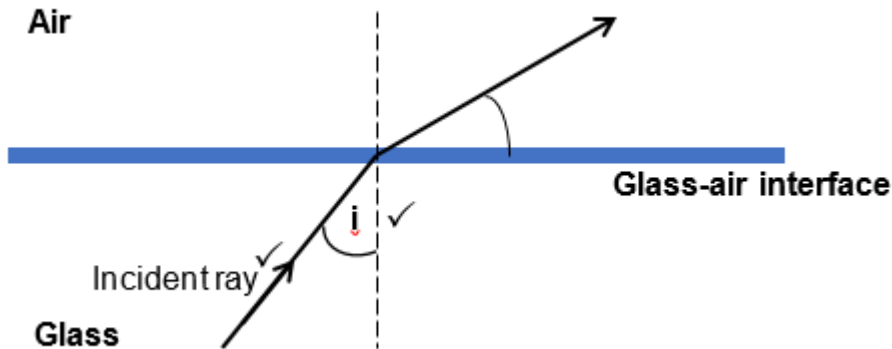

Marking Rubric : Ray diagram	
Criteria	Mark allocation
drawing and labeling the incident ray correctly	1 mark
Angle of Incidence indicated correctly.	1 mark

(2)

5.3 The ratio of the sine of the angle of incidence in one medium to the sine of the angle of refraction in the other medium is a constant. ✓✓ (2 or 0) (2)

5.4.1 $n_1 \sin\theta_1 = n_2 \sin\theta_2$ ✓
 $1,5 \cdot \sin 35^\circ = 1 \cdot \sin \theta_2$ ✓
 $\theta_2 = \hat{r} = 59,36^\circ$ ✓ (4)

5.4.2 $n = \frac{c}{v}$ ✓
 $1,5 = \frac{3 \times 10^8}{v}$ ✓
 $v = 2,00 \times 10^8 \text{ m}\cdot\text{s}^{-1}$ ✓ (3)

5.5.1 It is the angle of incidence for which the angle of refraction is 90° . ✓✓ (2)

5.5.2 $n_1 \sin \theta_1 = n_2 \sin \theta_2 \checkmark$ (Accept $\sin \hat{c} = \frac{1}{n}$)

$1,5 \sin \hat{c} = 1 \sin 90^\circ \checkmark$

$\hat{c} = 41,81^\circ \checkmark$

The angle of incidence is greater than/exceeds the critical angle of glass

(\hat{c}) \checkmark , therefore total internal reflection takes place. \checkmark

(5)

[20]**QUESTION SIX**

6.1 Light of a single frequency / wavelength. \checkmark (1)
(Do not accept light of the same colour).

6.2

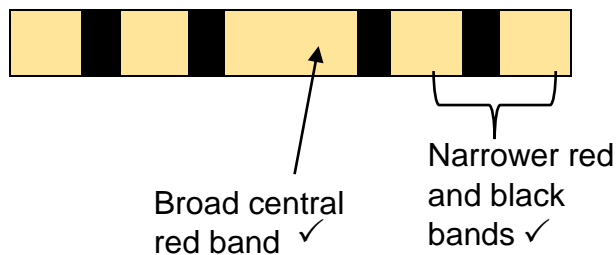

Marking Rubric : Diagram	
Criteria	Mark allocation
Drawing and labeling the central red band correctly	1 mark
Drawing and labeling narrower red and dark bands correctly	1 mark

(2)

6.3.1 Degree of diffraction / Position of first dark line from the centre. \checkmark (1)

6.3.2 Wavelength of light \checkmark (1)

6.3.3 Width of the slit / the distance of the slit from the screen \checkmark (1)

6.4 The greater the wavelength of light, the greater the degree of diffraction $\checkmark \checkmark$

OR

The smaller the wavelength of light, the smaller the degree of diffraction. $\checkmark \checkmark$

OR

Degree of diffraction is proportional to wavelength of the light. $\checkmark \checkmark$

(2)

[8]

QUESTION SEVEN**Negative marking in Q7.1.1**

7.1.1 Negatively charged ✓



The field lines move inwards into sphere B ✓

(2)

7.2.1 **OPTION 1:**

Using the law of conservation of charge,

 $(Q_A + Q_B) \text{ before contact} = (Q_A + Q_B) \text{ after contact}$ $\sum Q \text{ before contact} = \sum Q \text{ after contact}$ $-5 \times 10^{-6} + Q_B \checkmark = -3 \times 10^{-6} + -3 \times 10^{-6} \checkmark$ $Q_B = -1 \times 10^{-6} \text{ C} \checkmark$

} ✓ (Any one)

OPTION 2:

$$Q = \frac{Q_A + Q_B}{2} \checkmark$$

$$-3 \times 10^{-6} \checkmark = \frac{-5 \times 10^{-6} + Q_B}{2} \checkmark$$

$$Q_B = -1 \times 10^{-6} \text{ C} \checkmark$$

(4)

7.2.2 **Positive marking from Q 7.2.1**

A ✓

it had an excess of electrons. ✓

OR it had a greater excess of electrons than B. ✓**OR** it had more electrons than B. ✓

(2)

[8]

QUESTION EIGHT

8.1 $F = \frac{k Q_1 Q_2}{r^2}$ ✓
 $= \frac{9 \times 10^9 \cdot 5 \times 10^{-6} \cdot 8 \times 10^{-6}}{(0.25)^2}$ ✓
 $= 5,76 \text{ N}$ ✓ (4)

8.2 The electric field at a point is the electrostatic force experienced per unit positive charge placed at that point. ✓✓ (2 or 0) (2)

8.3 $E_{+5 \mu\text{C}} = \frac{k \cdot Q}{r^2}$ ✓ $E_{+8 \mu\text{C}} = \frac{k \cdot Q}{r^2}$ ✓
 $= \frac{9 \times 10^9 \cdot 5 \times 10^{-6}}{(0.25 - X)^2}$ ✓ $= \frac{9 \times 10^9 \cdot 8 \times 10^{-6}}{(X)^2}$ ✓

$$\left. \begin{array}{l} E_{\text{net}} = 0 \\ \frac{9 \times 10^9 \cdot 5 \times 10^{-6}}{(0.25 - X)^2} = \frac{9 \times 10^9 \cdot 8 \times 10^{-6}}{(X)^2} \end{array} \right\} \text{✓ (Any one)}$$

$$X = 0,14 \text{ m}$$

(6)
[12]**QUESTION NINE**

9.1 The magnitude of the induced emf across the ends of a conductor is directly proportional to the rate of change in the magnetic flux linkage with the conductor. ✓✓ (2 or 0) (2)

9.2.1 Anticlockwise ✓✓ (2)

9.2.2 The falling magnet creates a changing magnetic flux in the coil ✓✓ and an emf is therefore induced in the coil. (2)

OR The magnet is moving relative to the coil. ✓✓

9.3 $\varepsilon = \frac{-N \Delta \phi}{\Delta t}$ ✓
 $= \frac{-N \Delta B A \cos \theta}{\Delta t}$
 $= \frac{-50(0,18) \cdot (0,020)(\cos 60^\circ - \cos 0^\circ)}{0,10}$ ✓
 $= 0,90 \text{ V}$ ✓ (5)

9.4 The minus(-) means that the emf creates a current I and magnetic field B that oppose the change in flux. ✓✓ (2)

[13]

QUESTION TEN

10.1 Ohm's Law. ✓ (1)

10.2 It allows one to change/vary the current strength ✓ and potential difference across resistor R. ✓ OR to change the potential difference across the resistor. (2)

OR It varies the resistance ✓ in the circuit and hence the current. ✓

10.3 Open the switch in the circuit after taking a set of readings to allow the resistor to cool down. ✓
OR Do not keep the switch closed for long periods of time. ✓ (1)

10.4

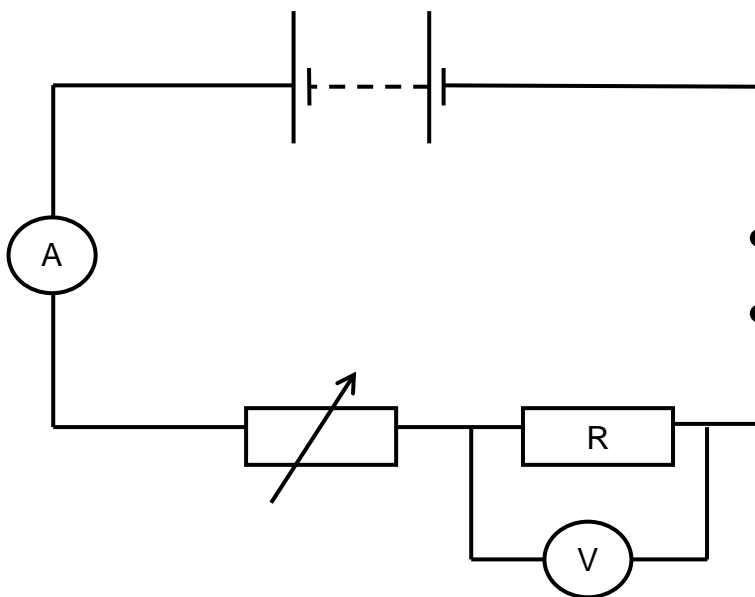

Marking Rubric : Circuit diagram	
Criteria	Mark allocation
Rheostat included with correct symbol.	1 mark
Resistor drawn, with voltmeter connected in parallel across the resistor.	1 mark
Ammeter connected in series to resistor.	1 mark
All components correctly connected to enable the verification of Ohm's Law.	1 mark

(4)

10.5
 10.5.1 Directly proportional **OR** $V \propto I$ **OR** $I \propto V$ ✓ (1)

10.5.2 Inverse of resistance **OR** $\frac{1}{R}$ ✓ OR conductivity (1)

10.5.3 0,15 A ✓ (1)

$$\begin{aligned}
 10.5.4 \quad \text{Gradient}(1/R) &= \frac{\Delta I}{\Delta V} \checkmark \\
 &= \frac{0,30 - 0}{12 - 0} \checkmark \\
 &= 0,03 \Omega^{-1} / (0,025 \Omega^{-1}) \\
 R &= 40 \Omega / 33 \Omega \checkmark
 \end{aligned}
 \tag{4}$$

10.6.1 B \checkmark (1)

10.6.2 **Negative marking from Q 10.5.1**

For a constant value of V ,

$$I_A > I_B \quad \checkmark$$

$$\frac{V}{I_A} < \frac{V}{I_B} \quad \checkmark$$

$$R_A < R_B$$

Therefore the resistor used in graph B has a larger resistance than A.

OR

For a constant value of V, the current in A is greater than that in B \checkmark .

$$\text{According to } R = \frac{V}{I} \checkmark$$

Hence R_A is less than R_B .

This implies graph B has a larger resistance than A.

OR

$$\text{gradient (A)} > \text{gradient (B)} \checkmark \checkmark \tag{2}$$

Therefore $R_B > R_A$.

[18]

QUESTION ELEVEN

$$\begin{aligned}
 11.1 \quad R &= \frac{V}{I} \checkmark \\
 &= \frac{12}{1,5} \checkmark \\
 &= 8 \Omega \checkmark
 \end{aligned}
 \tag{3}$$

11.2

$$I_{A1} = \frac{1}{2}$$

$$= \frac{1,5}{2} \checkmark$$

$$= 0,75 \text{ A} \checkmark$$

$$\frac{1}{R_P} = \frac{1}{R_1} + \frac{1}{R_2}$$

$$= \frac{1}{4} + \frac{1}{4}$$

$$R_P = 2 \Omega$$

$$V_{//} = I R \oplus$$

$$= 1,5 \cdot 2$$

$$= 3 \text{ V} \oplus$$

$$I_{A1} = \frac{V}{R} \oplus$$

(2)

11.3 **Positive marking from Q 11.2**

$$V = I R \checkmark$$

$$= 0,75 \times 2 \checkmark = 1,5 \text{ V} \checkmark$$

(3)

11.4 **Positive marking from Q 11.2**

$$V_P = V_1 + V_2$$

$$= 1,5 + 1,5 = 3 \text{ V} \checkmark$$

$$V_B = 12 - 3 \checkmark = 9 \text{ V}$$

$$R_B = \frac{V}{I} \checkmark$$

$$= \frac{9}{1,5}$$

$$= 6 \Omega \checkmark$$

(5)

11.5

$W = I^2 R \Delta t \checkmark$	OR	$W = VI \Delta t \checkmark$	OR	$W = \frac{V^2 \Delta t}{R} \checkmark$
$= \frac{(1,5)^2 (6)}{1} \checkmark (600) \checkmark$		$= \frac{9 (1,5)}{1} \checkmark (600) \checkmark$		$= \frac{(9)^2}{6} \checkmark \times (600) \checkmark$
$= 8100 \text{ J} \checkmark$		$= 8100 \text{ J} \checkmark$		$= 8100 \text{ J} \checkmark$

(4)

11.6 Equal to \checkmark

(1)

[18]

TOTAL MARKS: 150