



education

Department:
Education
PROVINCE OF KWAZULU-NATAL

**NATIONAL
SENIOR CERTIFICATE**

GRADE 10

PHYSICAL SCIENCES (P1)

(PHYSICS)

COMMON TEST

SEPTEMBER 2019

TIME: 2 Hours

MARKS: 150

This question paper consists of 14 pages, a data sheet and an answer sheet.

INSTRUCTIONS AND INFORMATION

1. Write your name and class (e.g. 10A) in the appropriate spaces on the ANSWER BOOK.
2. This question paper consists of 11 questions. Answer ALL questions in the ANSWER BOOK.
3. Hand in the ANSWER SHEET with the ANSWER BOOK.
4. Number the answers correctly according to the numbering system used in this question paper.
5. Leave ONE line between two sub-questions, e.g. between QUESTION 2.1 and QUESTION 2.2.
6. You may use a non-programmable calculator.
7. You may use appropriate mathematical instruments.
8. You are advised to use the attached DATA SHEETS.
9. Show ALL formulae and substitutions in ALL calculations.
10. Round off your final numerical answers to a minimum of TWO decimal places.
11. Give brief motivations, discussions, etc. where required.
12. Write neatly and legibly.

QUESTION 1: MULTIPLE-CHOICE QUESTIONS

Various options are provided as possible answers to the following questions. Each question has only ONE correct answer. Choose the answer and write only the letter (A-D) next to the question numbers (1.1 to 1.10) in the ANSWER BOOK, e.g. 1.11 E.

1.1 Which ONE of the following combinations is correct?

	Distance	Displacement	Velocity
A	scalar	scalar	scalar
B	scalar	vector	vector
C	vector	scalar	vector
D	vector	vector	scalar

(2)

1.2 A trolley runs down a slope, pulling a ticker tape behind it through a ticker timer. A portion of the tape is shown below and represents the distances moved during equal time intervals.

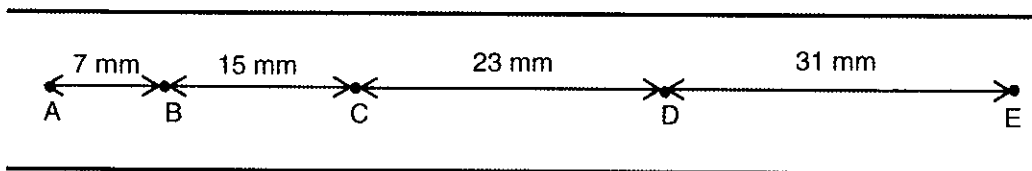

The ticker tape represents an **acceleration** that is ...

- A zero
- B uniform
- D increasing
- D decreasing

(2)

1.3 The motion of two objects, P and Q, are represented in the following position versus time graph.

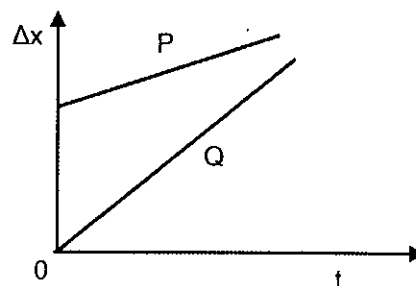

The graph indicates that ...

- A Q is moving faster than P.
- B P and Q are accelerating uniformly.
- C P and Q are on a collision course.
- D P and Q are moving in opposite directions.

(2)

- 1.4 Two cars, A and B, are lifted vertically upwards by a crane. If car A has 1,5 times the mass of car B and car A is lifted twice as high as car B, then how do their gravitational potential energies compare?

- A $E_{p(A)} = \frac{2}{3}E_{p(B)}$
 B $E_{p(A)} = 3E_{p(B)}$
 C $E_{p(A)} = \frac{1}{3}E_{p(B)}$
 D $E_{p(A)} = \frac{3}{4}E_{p(B)}$

(2)

- 1.5 An increase in the amplitude of a sound vibration will ...

- A increase the loudness but not the pitch.
 B increase the pitch but not the loudness.
 C decrease both the pitch and the loudness.
 D increase both the pitch and the loudness.

(2)

- 1.6 Which ONE of the following represents the change in wave properties when one moves from infra-red to ultraviolet in the electromagnetic spectrum?

	Frequency	Speed in a vacuum
A	Decreases	Decreases
B	Decreases	Remains constant
C	Increases	Remains constant
D	Increases	Increases

(2)

- 1.7 Which ONE of the following statements regarding the earth's magnetic field is FALSE?

- A It varies from place to place.
 B The magnetic south pole is the geographic north pole.
 C It is due to moving charges inside the hot interior of the earth.
 D The magnetic north and the geographic north are at the same location.

(2)

- 1.8 A negatively charged plastic comb is brought close to, but does not touch a small piece of paper. If the comb and the paper are now attracted to each other, then the original charge on the paper was ...

- A positive only
 B negative only
 C negative or neutral
 D positive or neutral

(2)

1.9 Refer to the circuit diagram below.

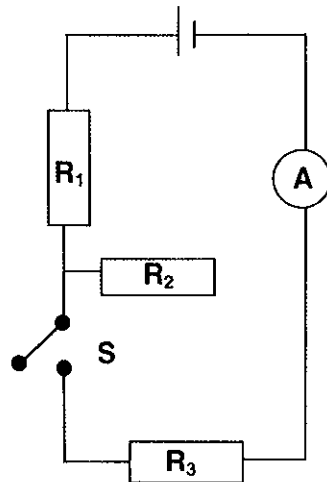

When switch S is now CLOSED, which ONE regarding the total resistance and current strength reading on ammeter A is correct?

	Total resistance	Current Strength on Ammeter A
A	Increases	Increases
B	Decreases	Increases
C	Increases	Decreases
D	Decreases	Decreases

(2)

1.10 The three resistors shown in the section of an electric circuit are **identical**.

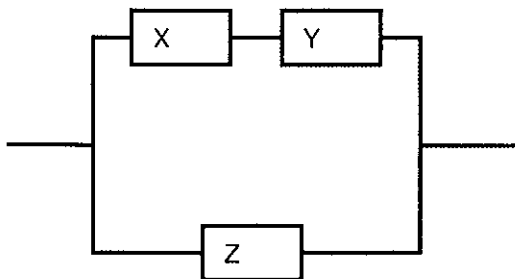

How do the potential differences across the individual resistors compare?

- A $V_X = V_Y = \frac{1}{2}V_Z$
- B $V_X = V_Y = V_Z$
- C $V_X = 2V_Z$
- D $V_X = \frac{1}{4}V_Z$

(2)

[20]

QUESTION 2

- 2.1 Define the term displacement in words. (2)
- 2.2 During a training session an athlete runs 140 m west along a straight road (A to B). He then runs 100 m east (B to C) and then finally 60 m east (C to D). The total time taken for this session took 2,5 minutes.
- 2.2.1 Draw a vector scale diagram to represent the three displacements (A to B; B to C and C to D). Label all the vectors clearly. (Use a scale of 1cm = 20m) (3)
- 2.2.2 On the vector scale diagram draw and indicate the resultant displacement for his motion. (1)
- 2.2.3 Calculate the total distance covered by the athlete. (1)
- 2.2.4 Determine his change in position at D, relative to A. (2)
- 2.2.5 Calculate the average velocity of the athlete. (4)
- 2.3 An aeroplane flies, in a straight line, due east to its destination which is 2 200 km away. The pilot wishes to maintain an average speed of $550 \text{ km}\cdot\text{h}^{-1}$ in order to arrive on time.

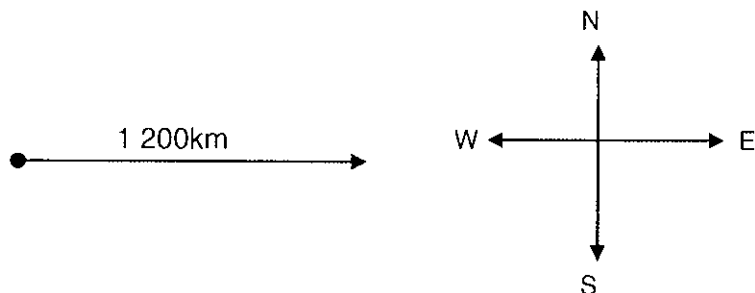

- 2.3.1 Calculate the time required (in hours) for him to reach his destination. (3)
- However, after flying the first 1100 km, he finds that the average speed so far has been only $500 \text{ km}\cdot\text{h}^{-1}$.
- 2.3.2 Calculate the time taken to cover the first 1 100 km. (2)
- 2.3.3 Determine the speed at which the pilot should fly for the rest of the trip if he still wishes to arrive on time. (3)

[21]

QUESTION 3

The velocity versus time graph below illustrates the motion of a train that is initially travelling in a SOUTHERLY direction. Its initial position at time $t = 0\text{s}$ is taken as 0 m .

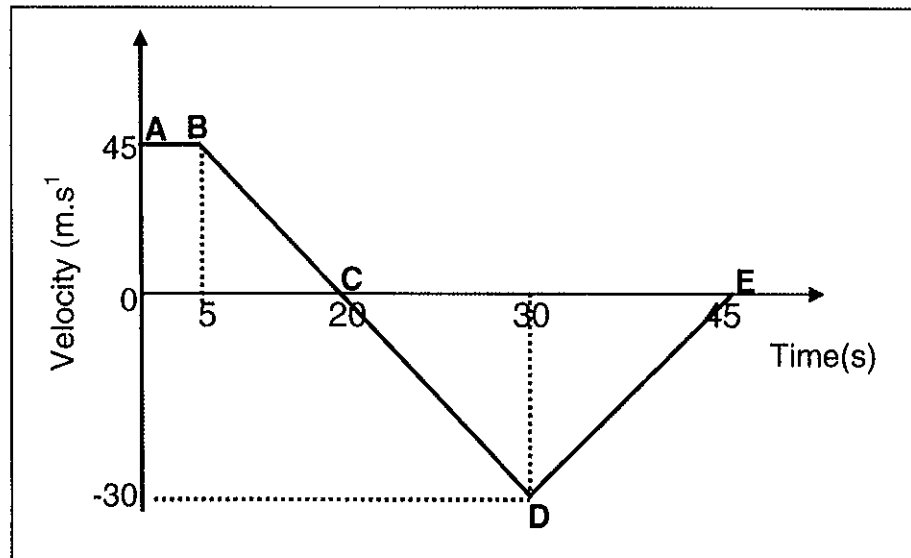

- 3.1 Explain why the train has a zero acceleration during interval **AB**. (1)
- 3.2 Why is the acceleration during interval **BC** EQUAL in magnitude to the acceleration during interval **CD**? (1)
- 3.3 Why does the train still experience a **NEGATIVE** acceleration during interval **CD** even though its velocity is increasing? (1)
- 3.4 Use the graph only (**NOT** equations of motions) to calculate the **acceleration** of the train for the interval:
- 3.4.1 **BC** (3)
- 3.4.2 **DE** (2)
- 3.5 Use the graph only (**NOT** equations of motions) to calculate the:
- 3.5.1 displacement for the time interval **AE**. (6)
- 3.5.2 distance travelled for the time interval **AE**. (1)
- 3.6 Sketch an acceleration versus time graph for the train over the entire journey. Indicate all relevant acceleration and time values. (4)

[19]

QUESTION 4

A motor car is 100 m behind truck. Both the vehicles are travelling in the same direction at $72 \text{ km}\cdot\text{h}^{-1}$. The truck drives over a landmine, which explodes, causing it to stop at that point.

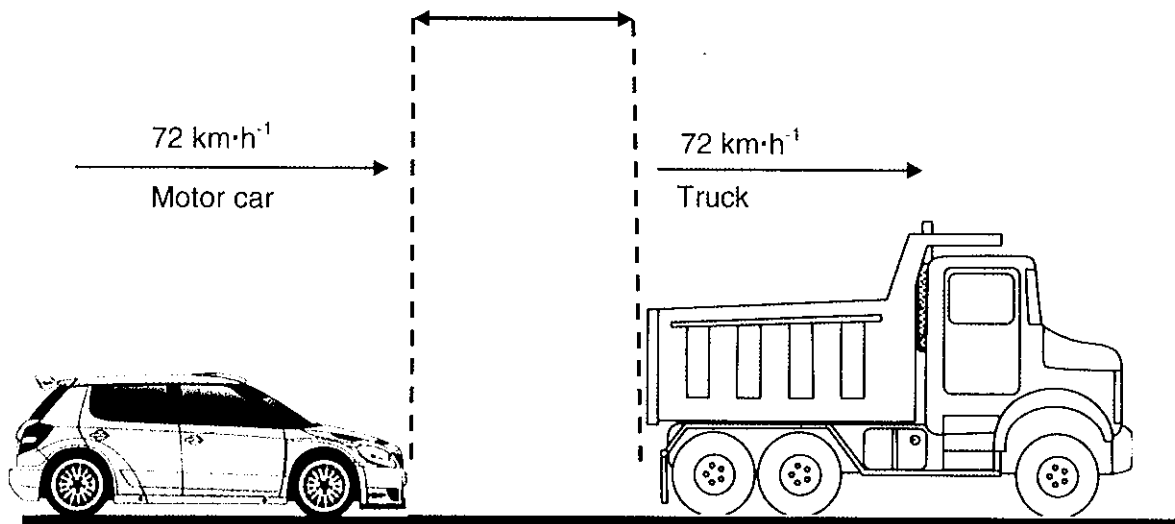

The driver of the motor car takes 0,4s before he applies the car's brakes. Once the brakes are applied the car slows down uniformly at $2,5 \text{ m}\cdot\text{s}^{-2}$.

- 4.1 Explain the term '**slows down uniformly at $2,5 \text{ m}\cdot\text{s}^{-2}$** '. (2)
- 4.2 Show that $72 \text{ km}\cdot\text{h}^{-1} = 20 \text{ m}\cdot\text{s}^{-1}$. (2)
- 4.3 Determine the distance travelled by the motor car during the 0,4 s reaction time. (3)
- 4.4 Calculate the total time taken for the motor car to come to rest, from the instant that the driver saw the landmine exploding. (4)
- 4.5 Will the motor car stop before reaching the wreck of the truck? Show all working in your answer. (5)

[16]

QUESTION 5

Vusi, of mass 45 kg, wants to reach an apple 2,5 m above the ground in an apple tree. He connects a swing to a high branch in an adjacent tree. The bottom of the swing is 1,15 m above the ground. He asks his friend, David, to push him in an effort to reach the apple. Ignore the effects of any frictional forces.

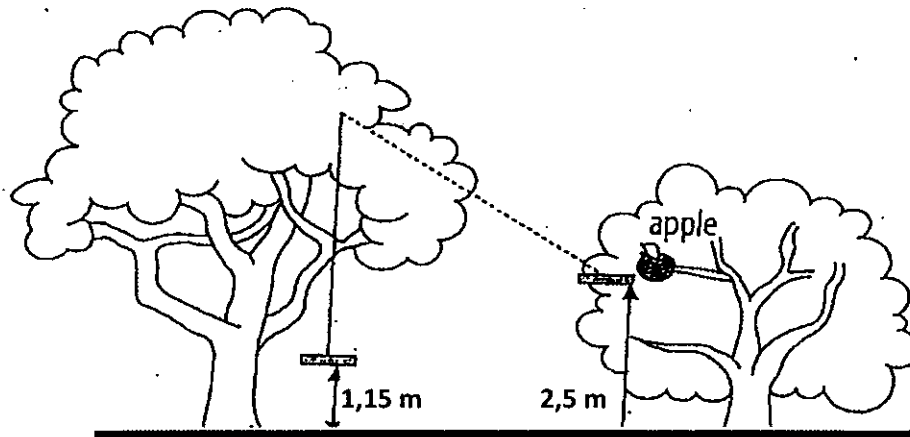

- 5.1 Define the term gravitational potential energy. (2)
- 5.2 Calculate the gravitational potential energy of Vusi on the swing before David pushes him. (3)
- 5.3 State the law of conservation of mechanical energy in words. (2)
- 5.4 Use energy principles to calculate the minimum speed with which David needs to push Vusi so that he can reach the apple in the tree. (4)
- 5.5 Why is it NOT possible to use equations of motion to calculate the speed mentioned in 5.4? (1)
- 5.6 Vusi now decides to **adjust the seat of the swing** so that it is **brought closer to the ground**. Will the speed with which David needs to push Vusi in order to reach the apple be **GREATER THAN**, **LESS THAN** or **THE SAME AS** that calculated in 5.4? Explain your answer **without using any calculation**. (5)

[17]

QUESTION 6

The diagram below shows two waves R and S that are travelling in the same medium at the same time.

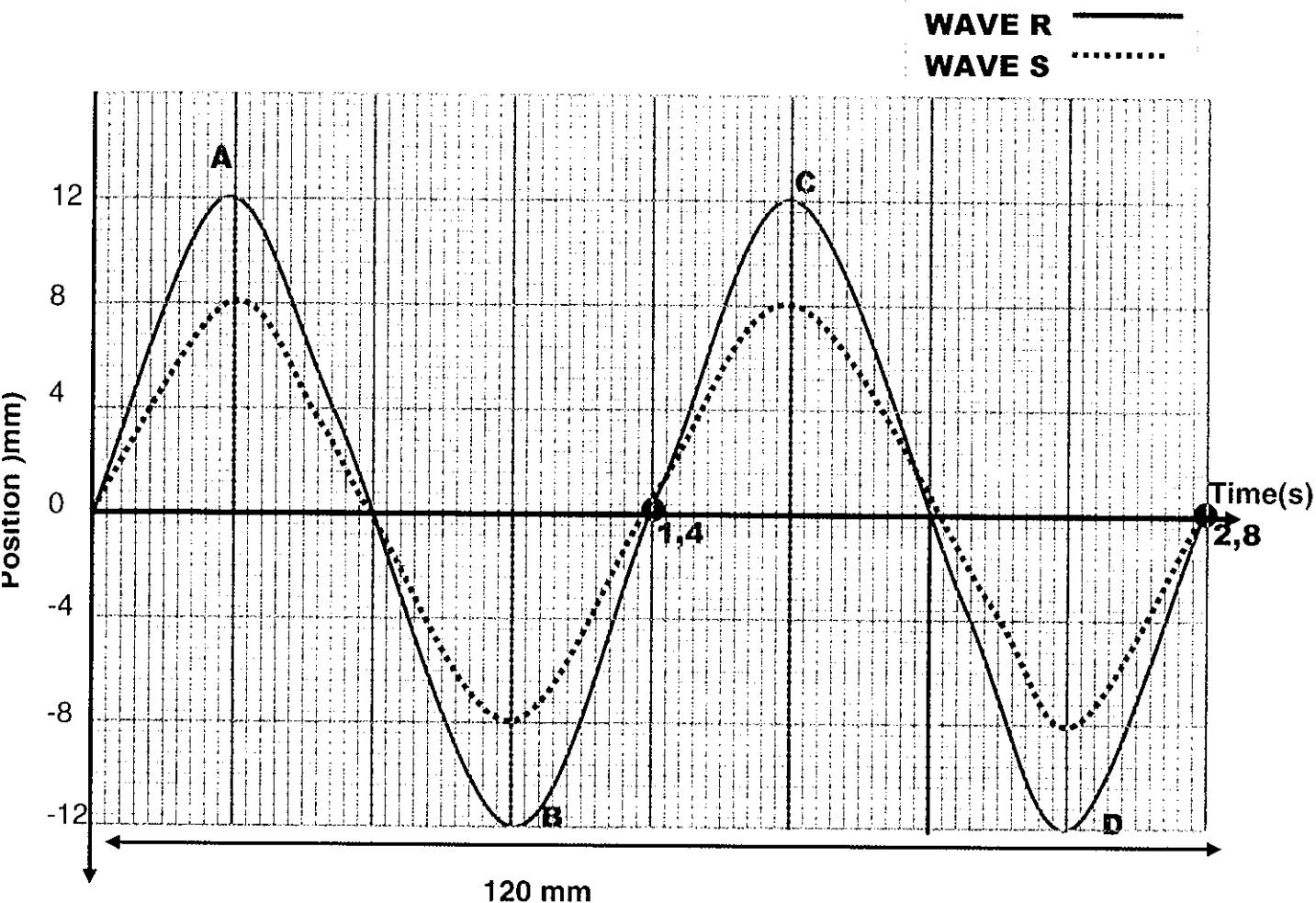

- 6.1 State the principle of superposition of waves. (2)
- 6.2 Determine the amplitude of the resultant wave when the two waves cross at $t = 0,35\text{s}$ (1)
- 6.3 What type of interference is illustrated when the two waves cross at $t = 0,35\text{s}$? (1)
- 6.4 Give ONE reason why points A and B, on **wave pattern R**, are out of phase. (1)
- 6.5 Refer to **wave pattern S** and calculate the:
- 6.5.1 frequency of the wave (3)
- 6.5.2 speed of the wave (3)

[11]

QUESTION 7

A group of learners decide to perform an experiment to determine the relationship between the wavelength and frequency of different sound notes. Specific sound notes are produced using a musical instrument. The frequency of the sound notes are measured and recorded in the table below.

Note played by learner	Wavelength (m)	Frequency (Hz)
A	4	84
B	5	68
C	7,69	44

- 7.1 Write down the investigative question for this experiment. (2)
- 7.2 Identify the controlled variable. (1)
- 7.3 Use the information from the table above to draw an accurate frequency versus $1/\text{wavelength}$ graph.
USE THE ATTACHED GRAPH PAPER. (3)
- 7.4 Calculate the gradient of this graph. (3)
- 7.5 What physical quantity does the gradient represent? (1)

[10]**QUESTION 8**

- 8.1 Define the term 'photon'. (2)
- 8.2 Two different sources of electromagnetic radiations have the following information:
- Source 1: its photon contains $2,65 \times 10^{-19} \text{J}$ of energy
Source 2: has a wavelength of $1 \times 10^{-13} \text{m}$
- 8.2.1 Calculate the energy of a photon from **source 2**. (4)
- 8.2.2 Which source (1 or 2) has the greater penetrating ability? Explain. (2)

[8]

QUESTION 9

9.1 What is meant by the term 'ferromagnetic substance'? (2)

9.2 Refer to the three bar magnets shown below.

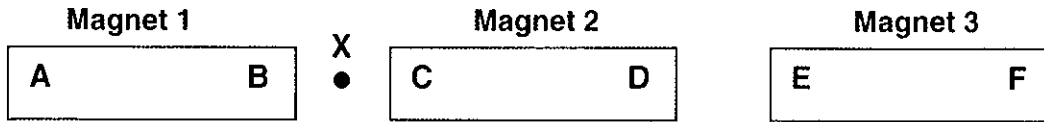

The following information is given:

- Pole B repels pole C
- Pole D attracts pole E
- Pole F is a north pole

Draw the magnetic field pattern around **region X**, as a result of **both** magnets 1 and 2. (3)

[5]

QUESTION 10

Two identical spheres X and Y, suspended from a ceiling, are placed a small distance apart, as shown in the diagram below.

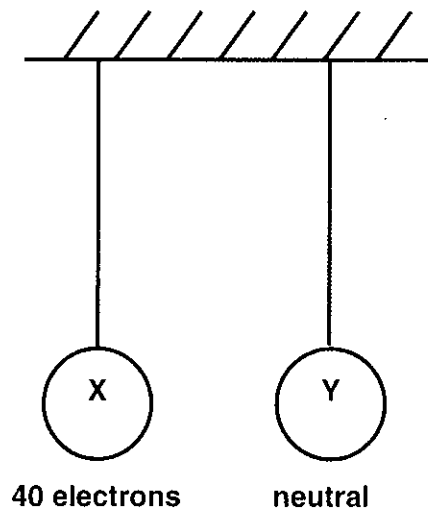

Sphere X has an excess of 40 electrons while sphere Y is neutral.

10.1 Calculate the charge on sphere X. (2)

10.2 Name the principle used to answer 10.1. (1)

The two spheres are now allowed to touch each other and are then separated.

- 10.3 Will electrons be transferred from X to Y or from Y to X? (1)
- 10.4 Calculate the final charge on sphere X after separation. (3)
- 10.5 Name the principle used to answer 10.4. (1)
- [8]**

QUESTION 11

Study the circuit diagram below. Ignore the resistance of the battery and the wires. Switch S is initially closed. The battery transfers 3×10^4 J of energy for every $2,5 \times 10^3$ C that flows through the circuit.

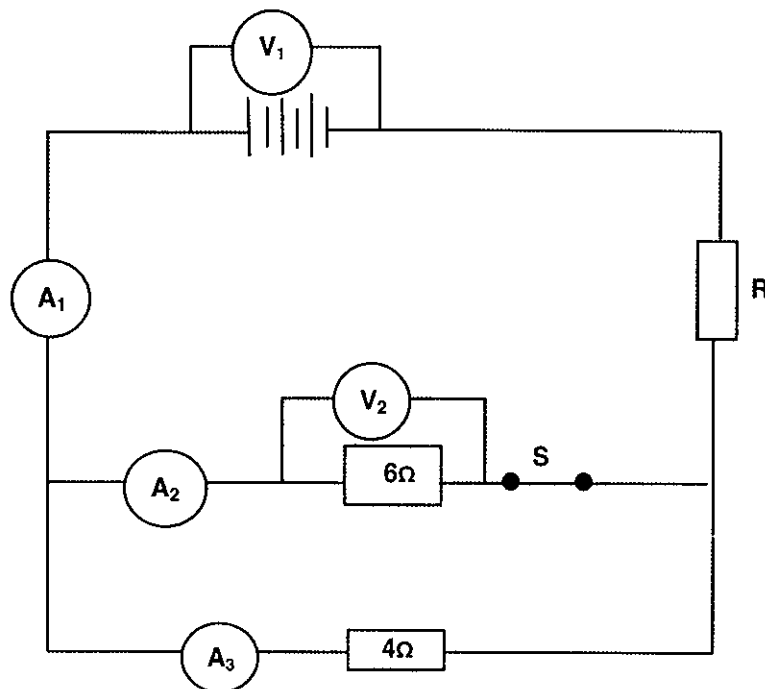

- 11.1 Define the term 'terminal potential difference'. (2)
- 11.2 Determine the reading on voltmeter V_1 . (3)
- 11.3 Determine the reading on ammeter A_1 if 3,24C of charge flows through it in 2 seconds. (3)

11.4 If the reading on ammeter A_2 is 0,65A then determine the reading on ammeter A_3 . (1)

11.5 If the total resistance of the circuit is $7,4\Omega$ then determine the resistance of resistor R. (5)

Switch S is now OPENED.

11.6 What will be the reading on voltmeter V_2 ? (1)

[15]

TOTAL MARKS: 150

**DATA FOR PHYSICAL SCIENCES
PAPER 1 (PHYSICS)**

TABLE 1: PHYSICAL CONSTANTS/TABEL 1: FISIESTE KONSTANTES

NAME/NAAM	SYMBOL/SIMBOOL	VALUE/WAARDE
Acceleration due to gravity <i>Swaartekragversnelling</i>	g	9,8 m·s ⁻²
Speed of light in a vacuum <i>Spoed van lig in 'n vakuum</i>	c	3,0 x 10 ⁸ m·s ⁻¹
Planck's constant <i>Planck se konstante</i>	h	6,63 x 10 ⁻³⁴ J·s
Charge on electron <i>Lading op elektron</i>	e	-1,6 x 10 ⁻¹⁹ C
Electron mass <i>Elektronmassa</i>	m _e	9,11 x 10 ⁻³¹ kg

$v_f = v_i + a \Delta t$	$\Delta x = v_i \Delta t + \frac{1}{2} a \Delta t^2$
$v_f^2 = v_i^2 + 2a \Delta x$	$\Delta x = \left(\frac{v_f + v_i}{2} \right) \Delta t$

WAVES, SOUND AND LIGHT/GOLWE, KLANK EN LIG

$v = f \lambda$	$T = \frac{1}{f}$
$E = hf$ or/of $E = h \frac{c}{\lambda}$	

ELECTROSTATICS/ELEKTROSTATIKA

$Q = \frac{Q_1 + Q_2}{2}$	$n = \frac{Q}{e}$
---------------------------	-------------------

ELECTRIC CIRCUITS/ELEKTRIESE STROOMBANE

$Q = I \Delta t$	$\frac{1}{R_p} = \frac{1}{R_1} + \frac{1}{R_2} + \dots$
$R_s = R_1 + R_2 + \dots$	$V = \frac{W}{q}$

ENERGY

$E_p = mgh$	$E_k = \frac{1}{2} mv^2$
-------------	--------------------------

ANSWER SHEET

QUESTION 7.3

NAME: _____

GRADE: _____

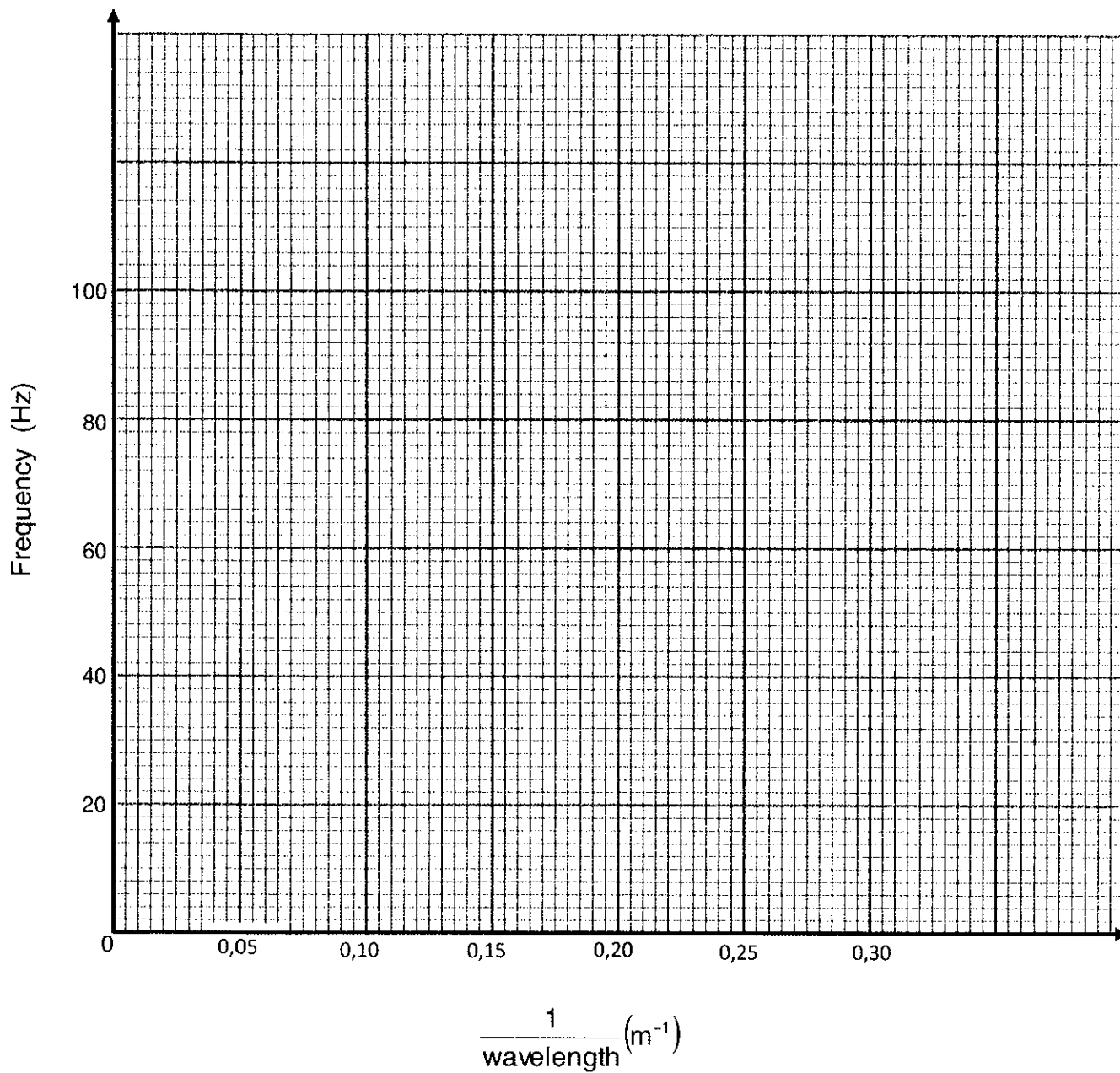



**NATIONAL
SENIOR CERTIFICATE**

GRADE 10

**PHYSICAL SCIENCES (P1)
COMMON TEST
SEPTEMBER 2019
MARKING GUIDELINES**

TIME: 2 Hours

MARKS: 150

These marking guidelines consists of 12 pages.

QUESTION 1

- 1.1 B ✓✓ (2)
- 1.2 B ✓✓ (2)
- 1.3 A ✓✓ (2)
- 1.4 B ✓✓ (2)
- 1.5 A ✓✓ (2)
- 1.6 C ✓✓ (2)
- 1.7 D ✓✓ (2)
- 1.8 D ✓✓ (2)
- 1.9 B ✓✓ (2)
- 1.10 A ✓✓ (2)
- (20)**

QUESTION 2

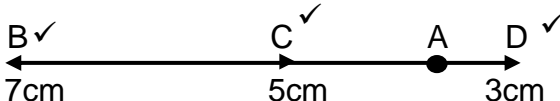
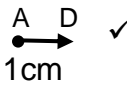
- 2.1 Difference in position in space ✓✓
OR
Change in position in space ✓✓ (2)
- 2.2
- 2.2.1  (3)
- 2.2.2  (1)
- 2.2.3 300 m ✓ (1)
- 2.2.4 20 m ✓ east ✓ (2)

2.2.5 ⊕ POSITIVE MARKING FROM 2.2.2

$$v = \frac{\Delta x}{\Delta t} \quad \checkmark$$

$$= \frac{20}{150} \quad \checkmark$$

$$= 0,13 \text{ m} \cdot \text{s}^{-1} \text{ east} \quad \checkmark$$

(4)

2.3

2.3.1

$$v = \frac{D}{\Delta t} \quad \checkmark$$

$$550 = \frac{2200}{\Delta t} \quad \checkmark$$

$$\Delta t = 4 \text{ h}$$

(3)

2.3.2

$$v = \frac{D}{\Delta t}$$

$$500 = \frac{1100}{\Delta t} \quad \checkmark$$

$$\Delta t = 2,2 \text{ h}$$

(2)

2.3.3

for the rest of the trip :

$$D = (2\,200 - 1\,100) = 1\,100 \text{ km}$$

$$\Delta t = (4 - 2,20) = 1,8 \text{ h}$$

$$v = \frac{D}{\Delta t}$$

$$= \frac{1\,100}{1,80} \quad \checkmark$$

$$= 611,11 \text{ km} \cdot \text{h}^{-1} \quad \checkmark$$

(3)

[21]

QUESTION 3

3.1 Its velocity is constant ✓ (1)

3.2 The gradient / slope (for BCD) is the same. ✓ (1)

OR

The gradient is constant ✓

3.3 The train is now moving opposite to its original direction. ✓ (1)

OR

It is moving northwards ✓

3.4.1 $a = \text{gradient} \checkmark$ OR $a = \frac{\Delta y}{\Delta x}$

$$= \frac{0-45}{20-5} \checkmark$$

$$= -3\text{m} \cdot \text{s}^{-2}$$

(3)

$$a = \underline{3\text{m} \cdot \text{s}^{-2} \text{ northwards}} \checkmark$$

3.4.2

$$a = \frac{0 - (-30)}{45 - 30} \checkmark$$

$$= \frac{30}{15}$$

$$= \underline{2\text{m} \cdot \text{s}^{-2} \text{ northwards}} \checkmark$$

(2)

3.5

3.5.1

$\Delta x = \text{area under the graph}$

OR

$$= (1 \times b) + \left(\frac{1}{2} b \times h \right) + \left(\frac{1}{2} b \times h \right)$$

$$= (5 \times 45) + \left(\frac{1}{2} \times 15 \times 45 \right) + \left(\frac{1}{2} \times 25 \times [-30] \right)$$

$$= 225 + 337,50 + (-375)$$

$$= \underline{187,50\text{m southwards}}$$

(6)

$$3.5.2 \quad D = 225 + 337.50 + 375 \quad (1)$$

$$= \underline{937,50\text{m}} \checkmark$$

3.6 POSITIVE MARKING FROM 3.4.1 AND 3.4.2

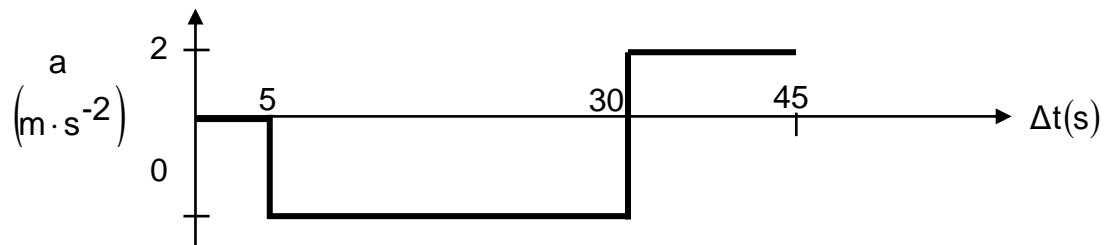

✓	Correct labels and units on both axes
✓	Horizontal line where $a=0\text{m}\cdot\text{s}^{-2}$ and $\Delta t = 5\text{s}$
✓	Horizontal line where $a=-3\text{m}\cdot\text{s}^{-2}$ and $\Delta t = 5 - 30\text{s}$
✓	Horizontal line where $a=2\text{m}\cdot\text{s}^{-2}$ and $\Delta t = 30 - 45\text{s}$

(4)

[19]**QUESTION 4**

4.1 The velocity decreases ✓ by $2.5 \text{ m}\cdot\text{s}^{-1}$ every second ✓

(2)

$$4.2 \quad \left. \begin{array}{l} \checkmark \\ \frac{72000\text{m}}{3600\text{s}} \end{array} \right\} = 20\text{m}\cdot\text{s}^{-1}$$

(2)

4.3 **OPTION 1**

$$\begin{aligned} \text{Distance} &= \text{speed} \times \text{time} \checkmark \\ &= 20 \cdot 0,4 \checkmark \\ &= 8\text{m} \checkmark \end{aligned}$$

OPTION 2

$$\begin{aligned} \Delta x &= v_i \Delta t + \frac{1}{2} \cdot a \cdot \Delta t^2 \checkmark \\ &= 20 \cdot 0,4 + 0 \checkmark \\ &= 8\text{m} \checkmark \end{aligned}$$

OPTION 3

$$\begin{aligned} \Delta x &= \left(\frac{v_f + v_i}{2} \right) \Delta t \checkmark \\ &= \frac{20 + 20}{2} \cdot 0,4 \checkmark \\ &= 8\text{m} \checkmark \end{aligned}$$

(4)

$$4.4 \quad v_f = v_i + a\Delta t \quad \checkmark$$

$$\quad \quad \quad \checkmark \quad \quad \quad \checkmark$$

$$\quad \quad \quad 0 = 20 + (-2,5)\Delta t$$

$$\Delta t = 8\text{s}$$

$$\Delta t_{\text{total}} = (0,5 + 8)$$

$$= 8,50\text{s} \quad \checkmark$$

(4)

4.5 **OPTION 1**

$$v_f^2 = v_i^2 + 2a\Delta x \quad \checkmark$$

$$(0)^2 = (20)^2 + 2(-2,5)\Delta x \quad \checkmark$$

$$\Delta x = 80\text{m} \quad \checkmark$$

\therefore motor car will stop \checkmark

Since it comes to a halt within $(80 + 8)\text{m}$ \checkmark (which is less than 100m)
[POSITIVE MARKING FROM 4.3]

OPTION 2

$$\Delta y = v_i\Delta t + \frac{1}{2}a\Delta t^2 \quad \checkmark$$

$$= 20(8) + \frac{1}{2}(-2,50)(8)^2 \quad \checkmark$$

$$= 80\text{m} \quad \checkmark$$

\therefore motor car will stop \checkmark

Since it covers $(80 + 8)\text{m}$ \checkmark (which is less than 100m)

(5)

[16]

QUESTION 5

5.1 The energy of an object due to its position in the gravitational field ✓
relative to some reference point ✓ (2)

5.2 $E_p = mgh$ ✓ **OR** $U = mgh$
 $= 45 \times 9,8 \times 1,15$ ✓
 $= 507,15 \text{ J}$ ✓ (3)

5.3 In an isolated system ✓ the total mechanical energy remains constant ✓ (2)

5.4 Mechanical Energy on Ground = Mechanical Energy at Apple " } EITHER ONE ✓
 $(E_p + E_k)_{\text{ground}} = (E_p + E_k)_{\text{at Apple}}$
 $= 507,15 + \frac{1}{2}(45)v^2 = \underline{(45 \times 9,8 \times 2,50) + 0}$ ✓
 $v = 5,14 \text{ m} \cdot \text{s}^{-1}$ ✓ (4)

5.5 Initial movement is not linear ✓
OR
Motion is "pendulum-like" ✓
OR
He is about to swing in an arc ✓ (1)

5.6 Greater than ✓
 E_p would decrease ✓ While E_k increases ✓ Since Mechanical Energy has to
remain constant ✓ Therefore when E_k increase then (v) must also increase ✓ (5)
[17]

QUESTION 6

6.1 When two waves occupy the same space at the same time, ✓ the resulting amplitude is the algebraic sum of the amplitudes of two waves ✓ (2)

6.2 20mm ✓ (1)

6.3 Constructive ✓ (1)

6.4 They are moving in opposite directions ✓ (1)

6.5.1 $f = \frac{1}{T}$ ✓
 $= \frac{1}{1,4}$ ✓
 $= 0,71 \text{ Hz}$ (3)

6.5.2 ⊕ POSITIVE MARKING FROM 6.5.1

$$\lambda = \frac{0,12}{2} = 0,06$$

$$v = f \times \lambda \quad \checkmark$$

$$= 0,71 \times 0,06$$

$$= 0,04 \text{ m} \cdot \text{s}^{-1} \quad \checkmark$$

(3)
[11]

QUESTION 7

7.1 Does the frequency of the note decrease as the wavelength increases? ✓✓

OR

Any question which mentions the two variables (frequency and wavelength) ✓✓ (2)

7.2 Temperature ✓ (of the surrounding air) (1)

7.3	✓✓	Plotting all 3 points correctly
	✓	Straight line graph passing through the origin

(3)

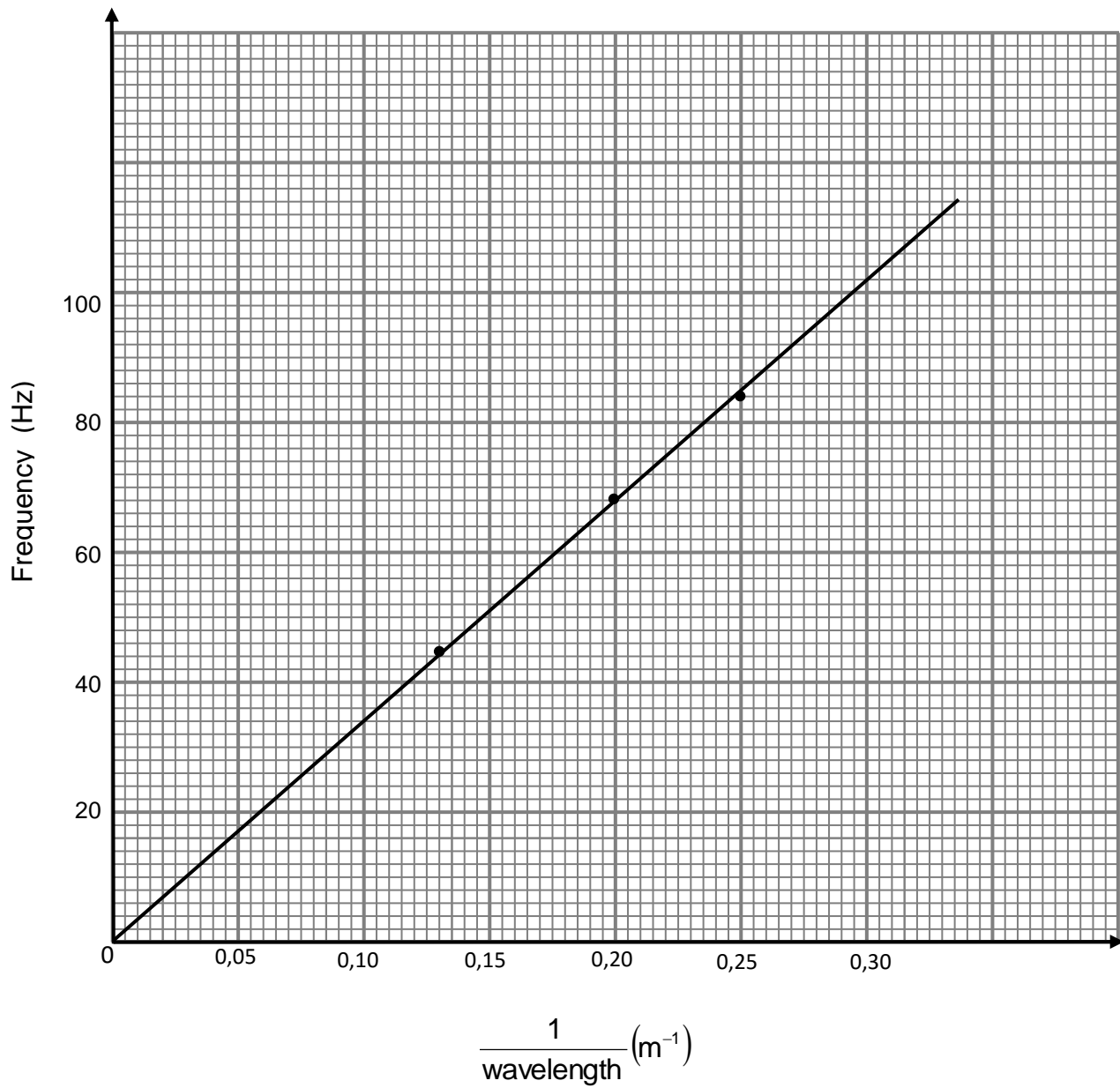

$$7.4 \quad \text{gradient} = \frac{84-44}{0,25-0,13} \quad \checkmark \checkmark$$

$$= 333,33 \quad \checkmark$$

OR

Any other suitable co-ordinates

(3)

7.5 Speed \checkmark (of sound)

(1)

[10]

QUESTION 8

8.1 A packet of energy $\checkmark \checkmark$ of light

(2)

$$8.2.1 \quad E = \frac{hc}{\lambda} \quad \checkmark$$

$$= \frac{(6,63 \times 10^{-34})(3 \times 10^8)}{(1 \times 10^{-13})} \quad \checkmark$$

$$= 1,99 \times 10^{-12} \text{ J} \quad \checkmark$$

(4)

8.2.2 Source 2 \checkmark

It has a greater amount of energy compared to that of source 1 \checkmark

(2)

[8]

QUESTION 99.1 A substance that is strongly attracted by magnets ✓✓**OR**A substance that is easily magnetized ✓✓

(2)

9.2

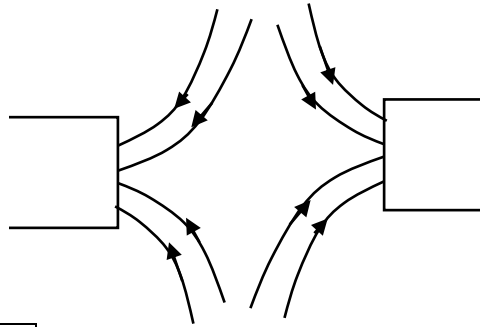

✓✓	Pattern
✓	direction

(3)
[5]**QUESTION 10**

10.1 $n = \frac{Q}{Q_e}$ ✓

$$40 = \frac{Q}{-1,6 \times 10^{-19}}$$

(2)

$$Q = -6,40 \times 10^{-18} \text{ C} \checkmark$$

10.2 Charge quantization ✓

(1)

10.3 X to Y ✓

(1)

10.4 ⊕ = POSITIVE MARKING FROM 10.1

$$Q = \frac{Q_1 + Q_2}{2} \checkmark$$

$$= \frac{(-6,40 \times 10^{-18}) + (0)}{2} \checkmark$$

$$= -3,20 \times 10^{-18} \text{ C} \checkmark$$

(3)

10.5 Conservation of charge ✓

(1)
[8]

QUESTION 11

11.1 The voltage measured across the terminals of the battery ✓
when charges are flowing in the circuit ✓ (2)

$$11.2 \quad V = \frac{W}{Q} \quad \checkmark$$

$$= \frac{3 \times 10^4}{2,5 \times 10^3} \quad \checkmark$$

$$= 12V \quad \checkmark \quad (3)$$

$$11.3 \quad I = \frac{Q}{\Delta t} \quad \checkmark$$

$$= \frac{3,24}{2} \quad \checkmark$$

$$= 1,62A \quad \checkmark$$

(3)

$$11.4 \quad 0,97A \quad \checkmark$$

(1)

$$11.5 \quad \frac{1}{R_P} = \frac{1}{R_1} + \frac{1}{R_2} \quad \checkmark$$

$$= \frac{1}{6} + \frac{1}{4} \quad \checkmark$$

$$\therefore R_g = 2,40\Omega \quad \checkmark$$

$$\therefore R_T = R_P + R_R$$

$$7,40 = 2,40 + R_R$$

$$R_R = 5\Omega \quad \checkmark$$

(5)

$$11.6 \quad \text{Zero} \quad \checkmark$$

(1)

[15]**TOTAL MARKS:****150**