



Province of the
EASTERN CAPE
EDUCATION



GRADE 10

PHYSICAL SCIENCES (P1)

OCTOBER 2022

Stanmorephysics.com

MARKS: 100

TIME: 2 HOURS

This question paper consists of 16 pages, including 1 data sheets

INSTRUCTIONS AND INFORMATION

1. Write your FULL NAME and SURNAME on the ANSWER SCRIPT.
2. The question paper consists of 9 questions. Answer ALL the questions in the ANSWER SCRIPT.
3. Start EACH question on a new page in the ANSWER SCRIPT.
4. Number the answers correctly according to the numbering system used in this question paper.
5. Leave ONE-line open between two subquestions for example between QUESTION 2.1 and QUESTION 2.2.
6. You may use a non-programmable calculator.
7. You may use appropriate mathematical instruments.
8. You are advised to use the attached DATA SHEETS.
9. Show ALL formulae and substitutions in ALL calculations.
10. Round off your final numerical answers to a minimum of TWO decimal places.
11. Give brief explanations, motivations, et cetera where required.
12. Write neatly and legibly.

QUESTION 1: MULTIPLE-CHOICE QUESTIONS

Four options are provided as possible answers to the following questions. Each question has only ONE correct answer. Choose the answer and write only the letter (A–D) next to the question number (1.1–1.10) in the ANSWER BOOK, for example 1.11 E

- 1.1 The physical quantity with both magnitude and direction is called...
- A Velocity
 - B Scalar
 - C Displacement
 - D Vector
- (2)

- 1.2 A girl paddles her canoe against the current in a river. The current flows at $0.6 \text{ m}\cdot\text{s}^{-1}$ downstream and girl paddles her canoe at $1.2 \text{ m}\cdot\text{s}^{-1}$ upstream.
- Which of the following is the resultant velocity of the canoe?
- A $1.8 \text{ m}\cdot\text{s}^{-1}$ upstream
 - B $1.8 \text{ m}\cdot\text{s}^{-1}$ downstream
 - C $0.6 \text{ m}\cdot\text{s}^{-1}$ upstream
 - D $0.6 \text{ m}\cdot\text{s}^{-1}$ downstream
- (2)

- 1.3 Consider the velocity-time graph of an object in motion below:

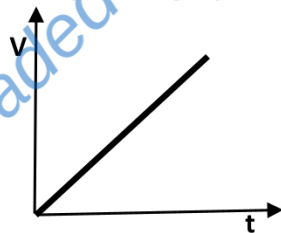

Which ONE of the graphs below represents the acceleration-time graph of the object?

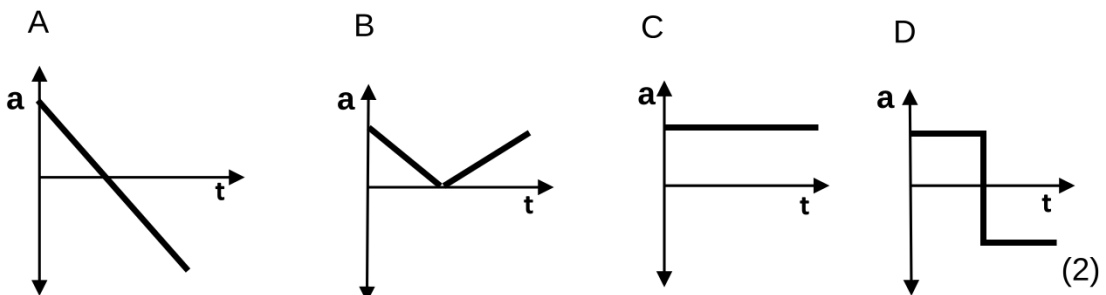

1.4 Which of the following statements is/are TRUE about an object travelling at a constant velocity?

- i) it travels in a straight line.
- ii) it travels at the same speed as the magnitude of its velocity.
- iii) its displacement increases by the same amount in each time interval.

- A i
- B i and ii
- C ii and iii
- D All of the above. (2)

1.5 A sphere is released from point **A**, as shown in the diagram below. It passes point **B** and reaches a maximum height at point **C**. Ignore the effects of air friction.

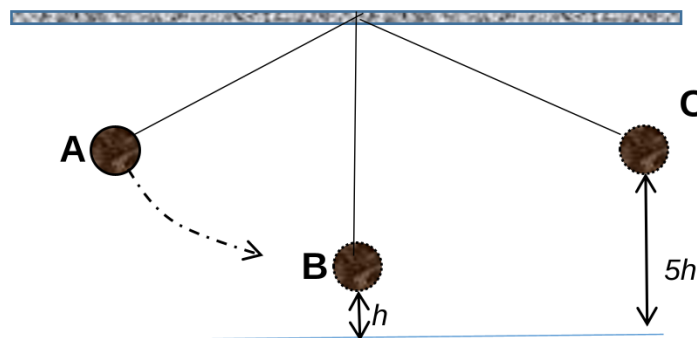

Which ONE of the statements below regarding the energy of the system is CORRECT?

- A The kinetic energy at **A** is equal to the mechanical energy at **A**.
- B The gravitational potential energy at **A** is equal to the kinetic energy at **B**.
- C The sum of the kinetic energy and gravitational potential energy at **B** is equal to the sum of the kinetic energy and gravitational potential energy at **C**.
- D The kinetic energy at **A** is equal to the gravitational potential energy at **C**. (2)

- 1.6 Two sources, **A** and **B** produce a transverse wave. Source **A** produces a transverse wave having a frequency of 40 Hz. If source **B** produces 1 600 waves in 8 seconds, its frequency will be...
- A 8 times the frequency of source **A**.
- B 5 times the frequency of source **A**.
- C less than the frequency of source **A**.
- D greater by 80 Hz than the frequency of source **A**. (2)
- 1.7 The wave in which the particles of the medium vibrate parallel to the direction of motion of the wave, is produced by...
- A An ambulance
- B an X-ray machine
- C ripples on the surface of water
- D electromagnetic waves (2)
- 1.8 Two waves, **A** and **B**, are produced by vibrating sources with the same frequency. **A** and **B** have wavelengths of 1 *m* and 3 *m* respectively. If the speed of wave **B** is *v*, the speed of wave **A** will be:
- A $\frac{1}{9}v$
- B $\frac{1}{3}v$
- C *v*
- D 3*v* (2)
- 1.9 A rod acquires a negative charge after it has been rubbed with wool. Which one of the following best explains this observation?
- A Positive charges are transferred from the rod to the wool.
- B Negative charges are transferred from the rod to the wool.
- C Positive charges are transferred from the wool to the rod.
- D Negative charges are transferred from the wool to the rod. (2)

1.10 Consider the circuit diagram with three resistors given below:

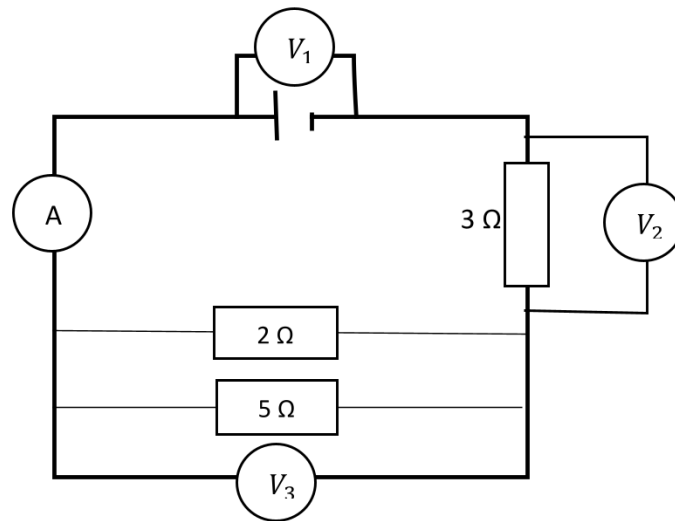

How will the readings on voltmeters V_1 , V_2 and V_3 compare with each other?

A $V_1 = V_2 = V_3$

B $V_1 > V_2 + V_3$

C $V_2 > V_1 + V_3$

D $V_1 = V_2 + V_3$

(2)

[20]

QUESTION 2

A group of people pulling the rope to the opposite directions as shown below. A woman applies a force of **16 N** eastwards. Two men apply forces of **19 N** and **21 N** against the woman.

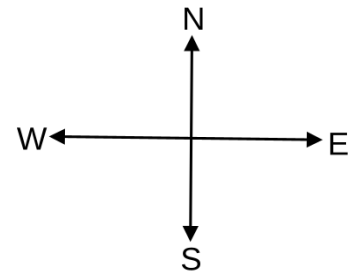

- 2.1 Define the term resultant vector. (2)
- 2.2 Determine the magnitude and the direction of the resultant vector exerted by men and woman on each other. (4)

[6]

QUESTION 3

The Banyana-banyana soccer team members were busy warming up for their match against Morocco during the Afcon played in Algeria. Below is a diagram that represents the measurements of the soccer field used by three players, Dlamini, Biyana and Jane.

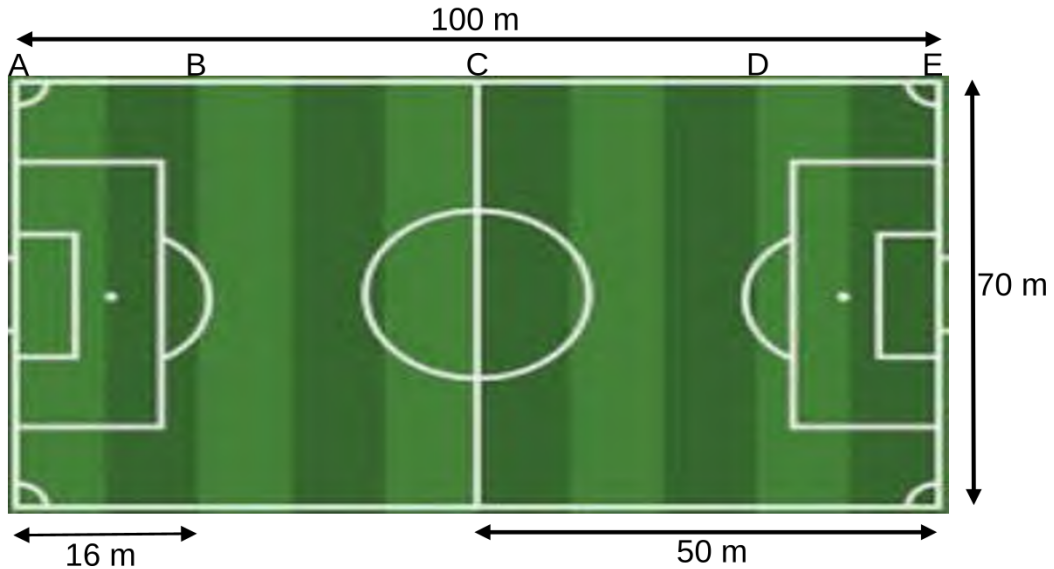

- 3.1 Define the term distance. (2)
- 3.2 Dlamini started at position **A**, jogged to position **E** and back to **A** in 1 minute.
 - 3.2.1 Determine the total distance covered by Dlamini. (1)
 - 3.2.2 Calculate Dlamini's average speed in $\text{m}\cdot\text{s}^{-1}$. (3)
- 3.3 Jane started warming up at point **C**. He jogged to position **E** and then ran to position **A** where he sat down.
 - 3.3.1 Use Vector scale diagram to represent the displacement of Jane. Show ALL the relevant information. Use the SCALE **1 cm = 10 m**. (4)
- 3.4 Biyana ran from **C** to **D** and back to **C**, and then from **C** to **E** in 1.5 minutes
 - 3.4.1 Calculate Biyana's average velocity. (4)

[14]

QUESTION 4

The truck mechanic conduct tests after the repair. A truck starts from rest at a traffic light and accelerates for 4 seconds in an easterly direction. A person on the road measures the change in position during equal time intervals. The results obtained are recorded in the table below.

Time (s)	Position (m)
0	0
1	10
2	20
3	30
4	40

- 4.1 For this test, write down the:
- 4.1.1 Independent variable. (1)
- 4.1.2 Dependent variable. (1)
- 4.2 Use the information in the table above and draw an accurate position-time graph on the graph paper on the attached ANSWER SHEET. (4)
- 4.3 Calculate the gradient of the graph. (4)

[10]

QUESTION 5

A man with a mass of 68 kg saw a boy floating under the bridge, which is 50 m above the top surface of water, as shown below. He makes a bungee jump from the bridge. Ignore the effects of air resistance.



- 5.1 Calculate the gravitational potential energy of the man just before he jumps from the bridge. (3)
- 5.2 State the law of conservation of *mechanical energy*. (2)
- 5.3 Use the law in QUESTION 5.2 to calculate the velocity of the man at a height of 20 m below the bridge. (5)

[10]



QUESTION 6

A transverse wave is generated in a string as shown in a picture below. It took three seconds for the wave to be completed.

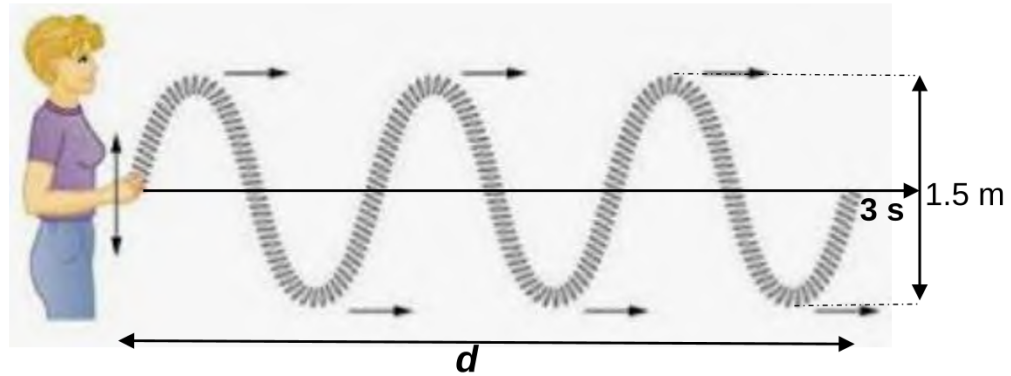

- 6.1 For the given wave, write down the:
- 6.1.1 Period. (1)
- 6.1.2 Amplitude. (1)
- 6.2 If the wave travels at $2 \text{ m}\cdot\text{s}^{-1}$ for 3 seconds, calculate the distance ***d***. (3)
- 6.3 Determine the wavelength. (2)
- 6.4 Calculate the frequency of the wave. (3)



[10]

QUESTION 7

The string shown below can be used to demonstrate the wave produces by the sound.

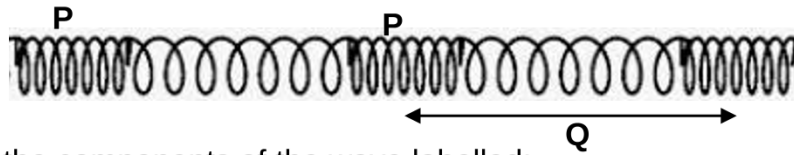

7.1 Identify the components of the wave labelled:

7.1.1 **P** (1)

7.1.2 **Q** (1)

7.2 The highest frequency that the human ear can hear is 20 kHz. A Dolphin produces a sound in order to locate prey in water.



7.2.1 If the dolphin produces sound waves of wavelength of 5 cm, determine by means of calculations, whether the frequency produced by Dolphin can be heard by human ear.

The speed of sound in water is $1\,480\text{ m}\cdot\text{s}^{-1}$. (4)

7.3 A boy standing between two buildings (**A** and **B**) started to call his sister that is inside building **B**.



A sound emitted by the boy strikes building **B** and returns back after 0.1 s. At the same instant, the sound produced by the boy returns back after 1.5 s from building **A**. If the speed of sound in air is $340\text{ m}\cdot\text{s}^{-1}$, calculate the distance between building **A** and **B**. (5).

[11]

QUESTION 8

Two spheres, **S** and **T**, on insulated stands, carry charges of $-7 \times 10^{-9} \text{ C}$ and $+5 \times 10^{-9} \text{ C}$ respectively as shown below.

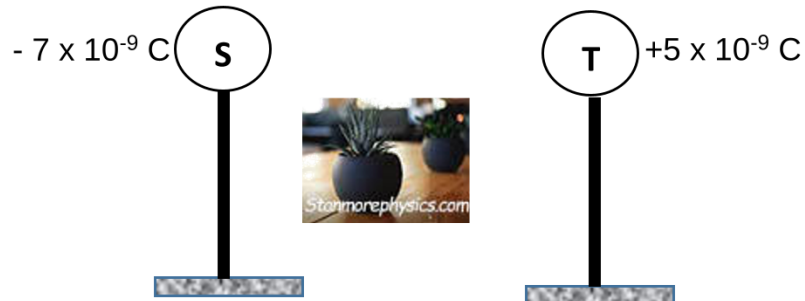

8.1 Which sphere (**S** or **T**) has an excess of electrons? (1)

8.2 Calculate the number of electrons in excess. (3)

THE SPHERES ARE NOW ALLOWED TO TOUCH EACH OTHER AND THEN SEPARATED AGAIN.

8.3 In which direction will electrons flow while spheres **S** and **T** are in contact? Write down only from **S** to **T** or from **T** to **S**. (1)

8.4 Calculate the new charge on each sphere after separation. (3)

[8]

QUESTION 9

In the circuit below, the connecting wires and the battery have negligible resistance.

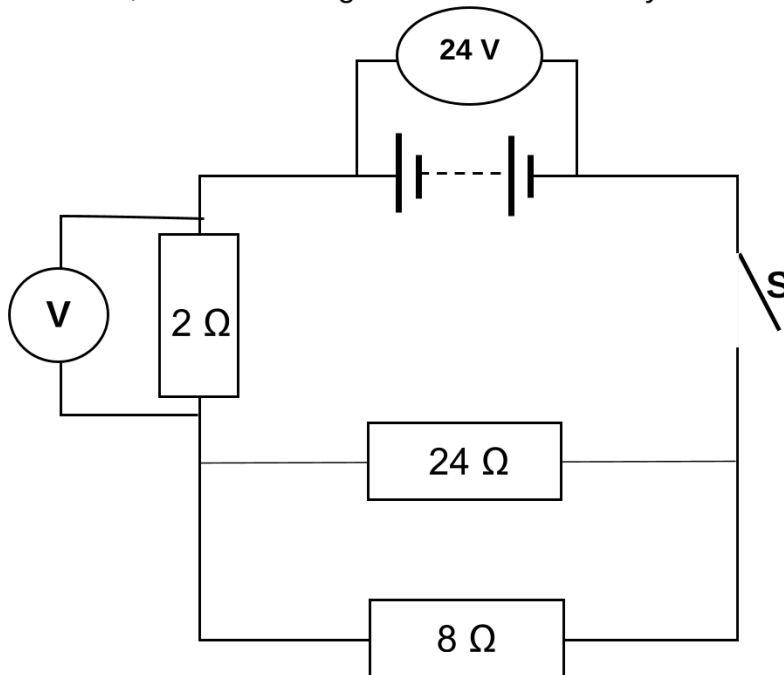

- 9.1 Define the term resistance. (2)
- 9.2 Calculate the:
- 9.2.1 Equivalent resistance of the resistors connected in parallel (3)
- 9.2.2 Total resistance of the circuit (2)
- 9.3 When the switch is closed, the voltmeter connected across the 2 Ω resistor measures 6 V. Determine the potential difference across the parallel combination. (1)
- 9.4 A charge of 18 C flows through the battery in 6 s. calculate the current in the 2 Ω resistor. (3)



[11]

TOTAL: 100

DATA FOR PHYSICAL SCIENCES GRADE 10

PAPER 1 (PHYSICS)

TABLE 1: PHYSICAL CONSTANTS

NAME/NAAM	SYMBOL/SIMBOOL	VALUE/WAARDE
Acceleration due to gravity <i>Swaartekragversnelling</i>	g	9,8 m·s ⁻²
Speed of light in a vacuum <i>Spoeed van lig in 'n vakuum</i>	c	3,0 x 10 ⁸ m·s ⁻¹
Planck's constant <i>Planck se konstante</i>	h	6,63 x 10 ⁻³⁴ J·s
Charge on electron <i>Lading op elektron</i>	e	-1,6 x 10 ⁻¹⁹ C
Electron mass <i>Elektronmassa</i>	m _e	9,11 x 10 ⁻³¹ kg

TABLE 2: FORMULAE

MOTION

$v_f = v_i + a \Delta t$	$\Delta x = v_i \Delta t + \frac{1}{2} a \Delta t^2$
$v_f^2 = v_i^2 + 2a \Delta x$	$\Delta x = \left(\frac{v_f + v_i}{2} \right) \Delta t$

WORK, ENERGY AND POWER

$U = mgh$ or/of $E_p = mgh$	$K = \frac{1}{2} mv^2$ or/of $E_k = \frac{1}{2} mv^2$
$E_M = E_k + E_p$ or/of $E_M = K + U$	

WAVES, SOUND AND LIGHT

$v = f \lambda$	$T = \frac{1}{f}$
$E = hf$ or/of $E = h \frac{c}{\lambda}$	

ELECTROSTATICS

$n = \frac{Q}{e}$	$Q = \frac{Q_1 + Q_2}{2}$
-------------------	---------------------------



ELECTRIC CIRCUITS

$Q = I \Delta t$	$\frac{1}{R_p} = \frac{1}{R_1} + \frac{1}{R_2} + \dots$
$R_s = R_1 + R_2 + \dots$	$V = \frac{W}{q}$

NAME _____

SURNAME _____

4.2

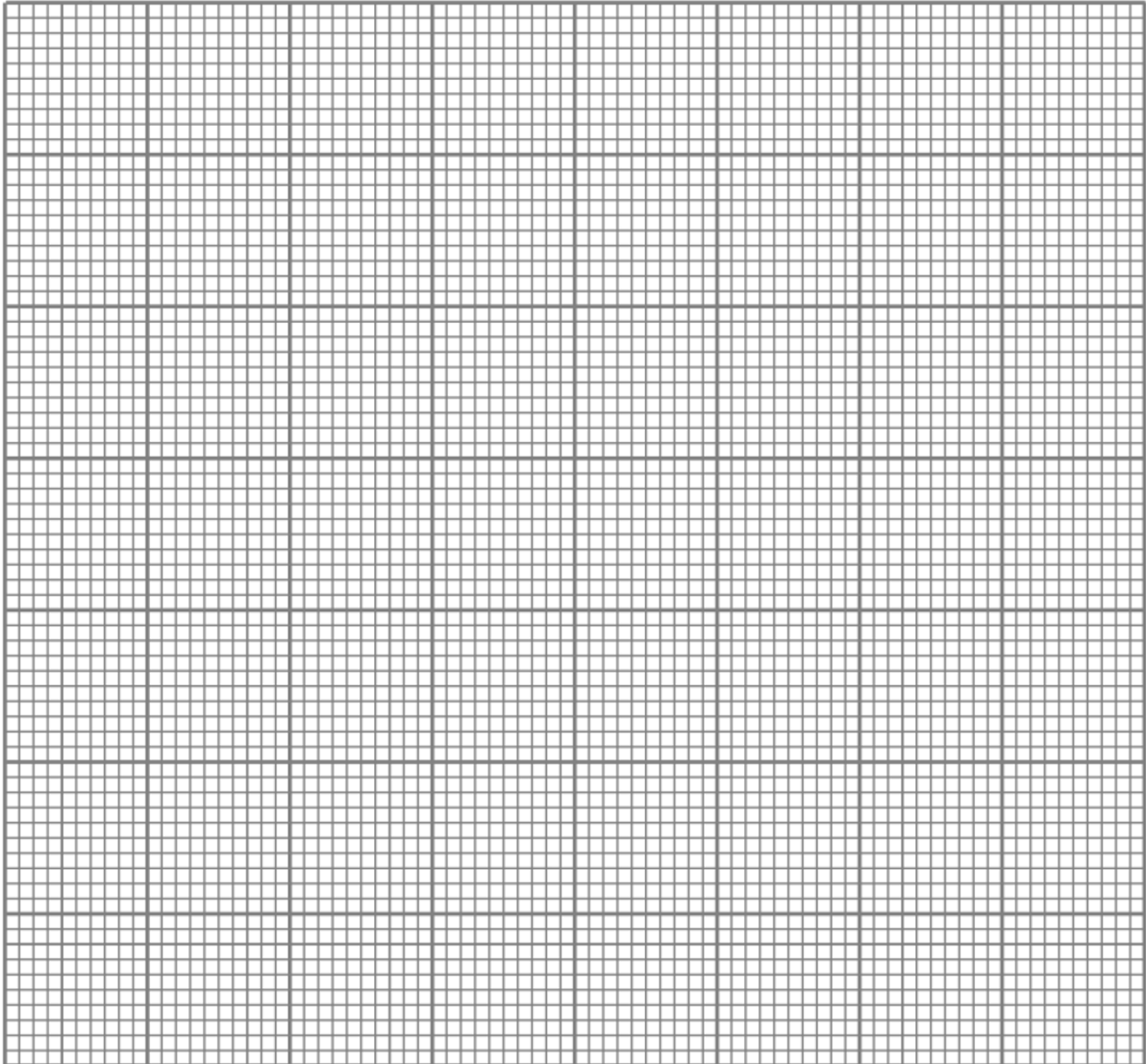



Province of the
EASTERN CAPE
EDUCATION

OR TAMBO INLAND DISTRICT



GRADE 10

PHYSICAL SCIENCES (P1)
OCTOBER 2022
MARKING GUIDELINES

MARKS: 100

These marking guidelines consists of 11 pages.

QUESTION 1

- 1.1 D✓✓ (2)
- 1.2 C✓✓ (2)
- 1.3 C✓✓ (2)
- 1.4 D✓✓ (2)
- 1.5 C✓✓ (2)
- 1.6 B✓✓ (2)
- 1.7 A✓✓ (2)
- 1.8 B✓✓ (2)
- 1.9 D✓✓ (2)
- 1.10 D✓✓ (2)

[20]

QUESTION 2

- 2.1 *Single vector having the same effect as two or more vectors together.* ✓✓ (2)
- 2.2 $F_m = 19\text{ N} + 21\text{ N}$
 $= 40\text{ N}$ ✓
 $F_R = F_m - F_w$
 $= 40\text{ N} - 16\text{ N}$ ✓
 $= 24\text{ N}$ ✓, Westwards. ✓ (4)

[6]

QUESTION 3

3.1 Total path length travelled. ✓✓ (2)

3.2.1 Distance = 100 m + 100 m
= 200 m ✓✓ (2)

3.2.2 Speed = $\frac{\text{Distance}}{\text{Time}}$ ✓
= $\frac{200}{60}$ ✓
= 3.33 m.s⁻¹ ✓ (3)

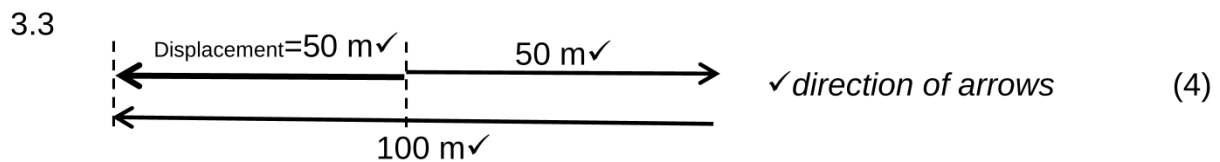

3.4 $\Delta x = CD - DC + CE$
= 34 m - 34 m + 50 m
= 50 m ✓

$v = \frac{\Delta x}{\Delta t}$ ✓
 $v = \frac{50}{90}$ ✓
= 0.56 m.s⁻¹ ✓ (4)

[14]

QUESTION 4

4.1.1 Time ✓ (1)

4.1.2 Position ✓ (1)

4.2 The graph below shows the change in position of the Truck during equal time intervals.

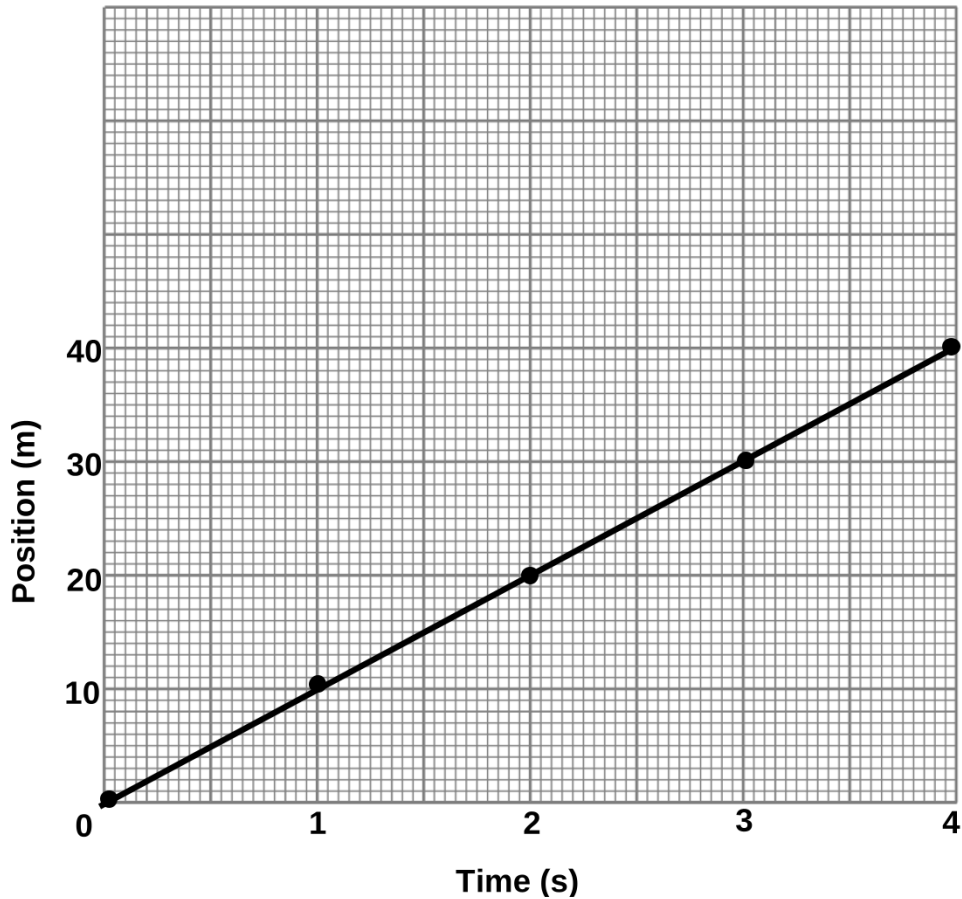

Heading	✓
Correct axis	✓
Shape	✓✓

(4)

4.3 Gradient = $\frac{\Delta x}{\Delta t}$ ✓

$$= \frac{40-0}{4-0} \checkmark$$

$$= 10 \text{ m}\cdot\text{s}^{-1} \checkmark$$

(4)

[10]

QUESTION 5

5.1 $E_p = mgh$ ✓
 $= (68) (9.8) (50)$ ✓
 $= 33\,320 \text{ J}$ ✓ (3)

5.2 *The total energy of an isolated system remains constant.* ✓✓ (2)

5.3 $(E_p + E_k)_{\text{top}} = (E_p + E_k)_{\text{bottom}}$ ✓
 $33\,320 + 0 = (68) (9.8) (30) + \frac{1}{2}(68) v^2$
 $33\,320 = 19\,992 + 34 v^2$
 $v = 19.80 \text{ m}\cdot\text{s}^{-1}$, downwards ✓ (5)

[10]

QUESTION 6

6.1.1 1 s ✓ (1)

6.1.2 $1.5 \text{ m} \div 2$
 $= 0.75 \text{ m}$ ✓ (1)

6.2 $v = \Delta x / \Delta t$ ✓
 $2 = d / 3$ ✓
 $d = 6 \text{ m}$ ✓ (3)

6.3 $\lambda = 6 \text{ m} \div 3$
 $= 2 \text{ m}$ ✓✓ (2)

6.4

OPTION 1	OPTION 2	OPTION 3
$v = f\lambda$ ✓ $2 = f (2)$ ✓ $f = 1 \text{ Hz}$ ✓	$f = \frac{\text{no. of waves}}{\text{time}}$ ✓ $f = \frac{3}{3}$ ✓ $f = 1 \text{ Hz}$ ✓	$f = \frac{1}{T}$ ✓ $f = \frac{1}{1}$ ✓ $f = 1 \text{ Hz}$ ✓

(3)

[10]

QUESTION 7

7.1.1 P - Compression✓ (1)

7.1.2 Q – Wavelength✓ (1)

7.2 $v = f\lambda$ ✓

$$1\,480 = f(0.05) \checkmark$$

$$f = 29\,600 \text{ Hz} \left. \vphantom{f} \right\} \checkmark$$

$$f = 29.60 \text{ kHz} \left. \vphantom{f} \right\} \checkmark$$

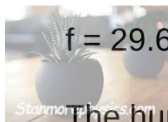

The human ear cannot hear the frequency produced by the Dolphin✓ (4)

7.3 $v = \Delta x / \Delta t$

$$340 = \Delta x / 0.1 \checkmark$$

$$\Delta x = 34 \text{ m} \checkmark$$

$$v = \Delta x / \Delta t$$

$$340 = \Delta x / 1.5 \checkmark$$

$$\Delta x = 510 \text{ m} \checkmark$$

$$\text{Distance} = 34 \text{ m} + 510 \text{ m}$$

$$= 544 \text{ m} \checkmark \quad (5)$$

[11]

QUESTION 8

8.1 S✓ (1)

8.2 $n = \frac{Q}{e}$ ✓
 $n = \frac{-7 \times 10^{-9}}{-1,6 \times 10^{-19}}$ ✓
 $= 4,38 \times 10^{10}$ electrons✓ (3)

8.3 S to T✓ (1)

8.4 $Q = \frac{Q_1 + Q_2}{2}$ ✓
 $= \frac{-7 \times 10^{-9} + 5 \times 10^{-9}}{2}$ ✓
 $= -1 \times 10^{-9}$ C✓ (3)

[8]

QUESTION 9

9.1 The ratio of the potential difference across a resistor to the current in the resistor. ✓✓ (2)

9.2.1 $R_{//} = \frac{R_1 \times R_2}{R_1 + R_2}$ ✓
 $= \frac{24 \times 8}{24 + 8}$ ✓
 $= 6 \Omega$ ✓ (3)



9.2.2 $R_T = R_s + R_{//}$
 $= 2 \Omega + 6 \Omega$ ✓
 $= 8 \Omega$ ✓ (2)

9.3 $V_{//} = 24 V - 6 V$
 $= 18 V$ (1)

9.4

OPTION 1	OPTION 2
$Q = I \Delta t$ $18 = I (6)$ $I = 3 A$	$R = \frac{V}{I}$ $2 = \frac{6}{I}$ $I = 3 A$

(3)

[11]

TOTAL: 100