



# education

DEPARTMENT: EDUCATION  
MPUMALANGA PROVINCE

**NATIONAL  
SENIOR CERTIFICATE**

**GRADE 12**

**PHYSICAL SCIENCES: PHYSICS (P1)**

**SEPTEMBER 2023**

**MARKS: 150**

**TIME: 3 hours**

*Stanmorephysics*

This question paper consists of 21 pages including 3 information sheets.

**INSTRUCTIONS AND INFORMATION**

1. Write your name on the ANSWER BOOK.
2. This question paper consists of ELEVEN questions. Answer ALL the questions in the ANSWER BOOK.
3. Start EACH question on a NEW page in the ANSWER BOOK.
4. Number the answers correctly according to the numbering system used in this question paper.
5. Leave ONE line between two subquestions, e.g. between QUESTION 2.1 and QUESTION 2.2.
6. You may use a non-programmable calculator.
7. You may use appropriate mathematical instruments.
8. Show ALL formulae and substitutions in ALL calculations.
9. Round off your FINAL numerical answer to a minimum of TWO decimal places.
10. Give brief motivations, discussions, etc. where required.
11. You are advised to use the attached DATA SHEETS.
12. Write neatly and legibly.



**QUESTION 1: MULTIPLE CHOICE QUESTIONS**

Various options are provided as possible answers to the following questions. Choose the answer and write only the letter (A–D) next to the question number (1.1 to 1.10) in the ANSWER BOOK, e.g. 1.11 D. Each question has only ONE correct answer.

- 1.1 Which ONE of the following groups of physical quantities are vectors?
- A Acceleration, speed and velocity
- B Mass, distance and acceleration
- C Acceleration, force and velocity
- D Electric field, current and charge (2)
- 1.2 In which ONE of the following cases is the resultant force acting on an object equal to zero?
- A An object moving with constant acceleration.
- B When the only force acting on the object is the gravitational force.
- C An object undergoes equal displacements every second.
- D An object moving with increasing acceleration. (2)
- 1.3 Which ONE of the examples stated below best describes weightlessness?
- A An object accelerates downwards towards the Earth at an acceleration of  $9,8 \text{ m}\cdot\text{s}^{-2}$ .
- B An object moving at a constant velocity upwards away from the ground.
- C An object moving at constant velocity downwards towards the ground.
- D An object that is accelerated upwards away from the ground by a constant applied force. (2)



- 1.4 The graph below indicates the net force exerted on an object over a period of time.

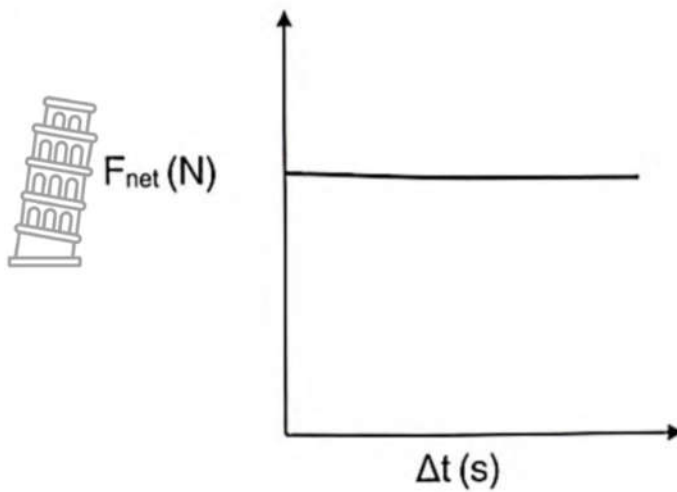

The area under the graph represents the .....of the object.

- A momentum
- B impulse
- C rate of change of momentum
- D acceleration

(2)



- 1.5 An object is dropped from a height,  $h$ , above the ground level. Ignore the effects of air resistance.

Which ONE of the following graphs represents the relationship between kinetic energy,  $E_k$ , and the height,  $h$ , above the ground the **BEST**?

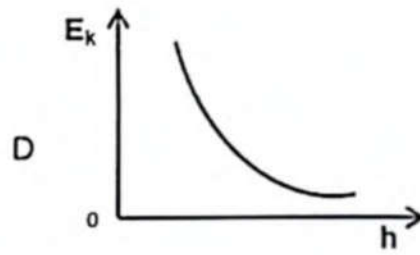
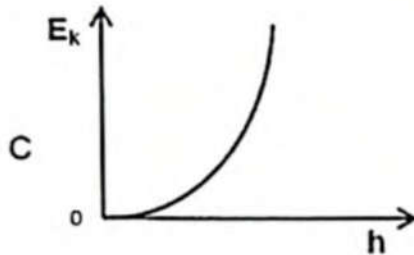
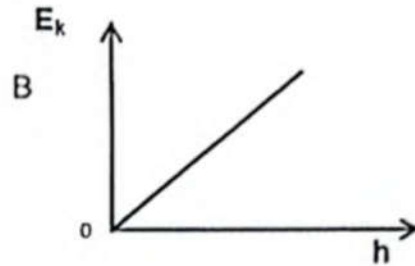
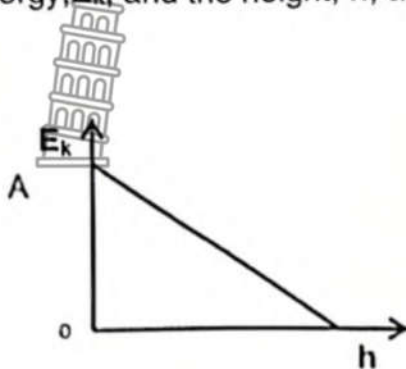

(2)

- 1.6 Which ONE of the following describes the effect of the Doppler shift on the spectral lines if the star moves AWAY from the earth?

The spectral lines...

- A shift to the red end of the spectrum.
- B shift to the blue end of the spectrum.
- C appear more dim.
- D show no change at all.

(2)





- 1.7 Two identical charges are placed a distance  $r$  from each other in a vacuum. Charge  $Q_1$  experiences an electrostatic force  $F$  due to charge  $Q_2$ . The charge on  $Q_2$  and the distance between the charges is changed.

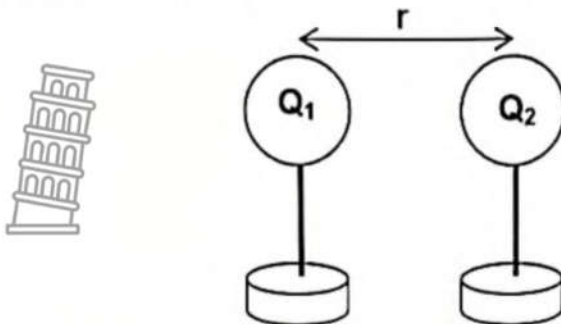

Which ONE of the following combinations will result in a force of  $16F$  exerted on  $Q_1$ ?

	Charge $Q_2$	Distance $r$
A	$\frac{1}{2} Q_2$	$2r$
B	$4 Q_2$	$\frac{1}{2} r$
C	$2 Q_2$	$\frac{1}{2} r$
D	$8 Q_2$	$2r$

(2)

- 1.8 Three identical bulbs are connected to a cell with internal resistance. The switch  $S$  is CLOSED as shown in the circuit diagram below.

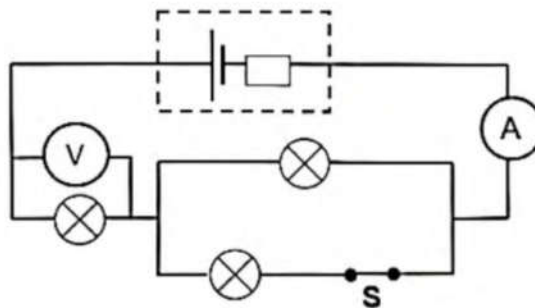

Switch  $S$  is now opened.

Which ONE of the following gives the CORRECT changes observed on the ammeter and voltmeter?

	AMMETER READING	VOLTMETER READING
A	Increases	Increases
B	Increases	Decreases
C	Decreases	Decreases
D	Decreases	Increases



(2)

- 1.9 In the graph below the solid curve shows how the emf produced by a simple generator changes with time. The broken curve shows the output of the same generator had been made to the generator.

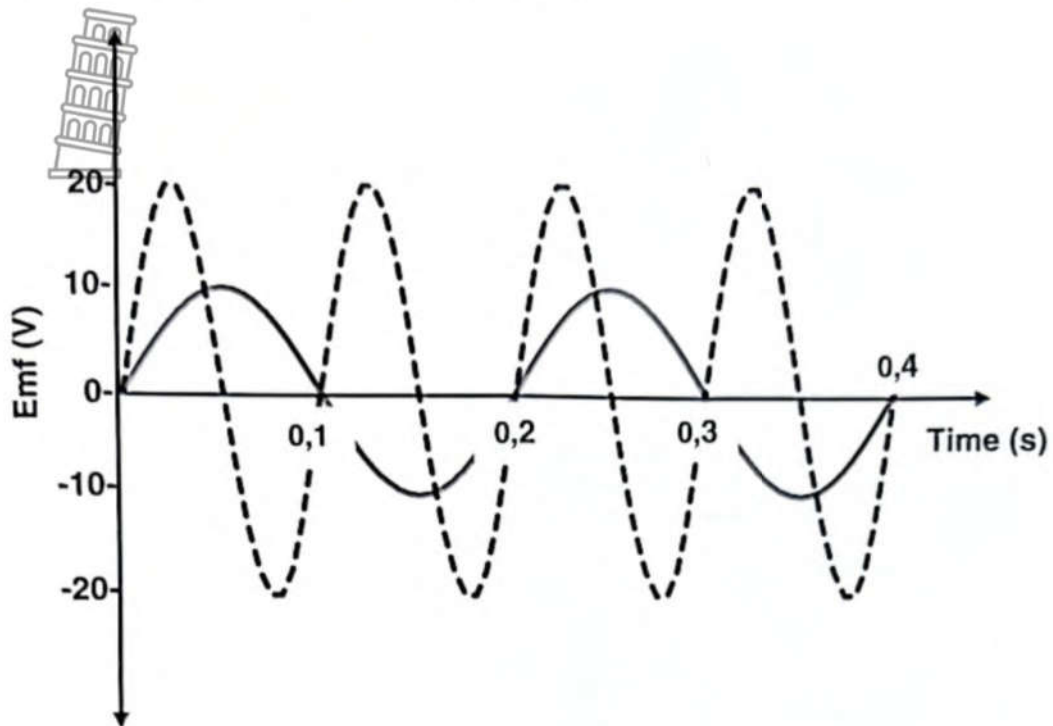

Which change has been made to result in the broken curve?

- A The number of windings in the coil is doubled.
- B The speed of rotation is doubled.
- C A split ring commutator is added.
- D The strength of the magnets is doubled.

(2)



- 1.10 The diagram below shows the possible transitions of electrons between ENERGY LEVELS ( $E_1$  to  $E_4$ ) in an atom of a specific element.

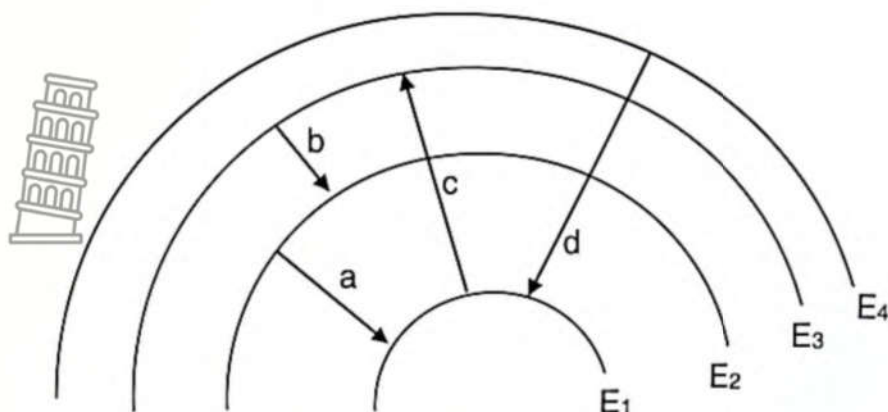

Which transition will produce the line of the SHORTEST WAVELENGTH on the emission spectrum of the element?

- A Transition a
- B Transition b
- C Transition c
- D Transition d

(2)

[20]





**QUESTION 2 (Start on a new page.)**

Block **A** with mass 4 kg, that is at rest on a rough horizontal table, is connected to another block **B** with mass 8 kg by a light inextensible string passing over a frictionless pulley.

A force  $F_1$  of magnitude 96 N is applied vertically upwards on block **B** as shown in the diagram below.

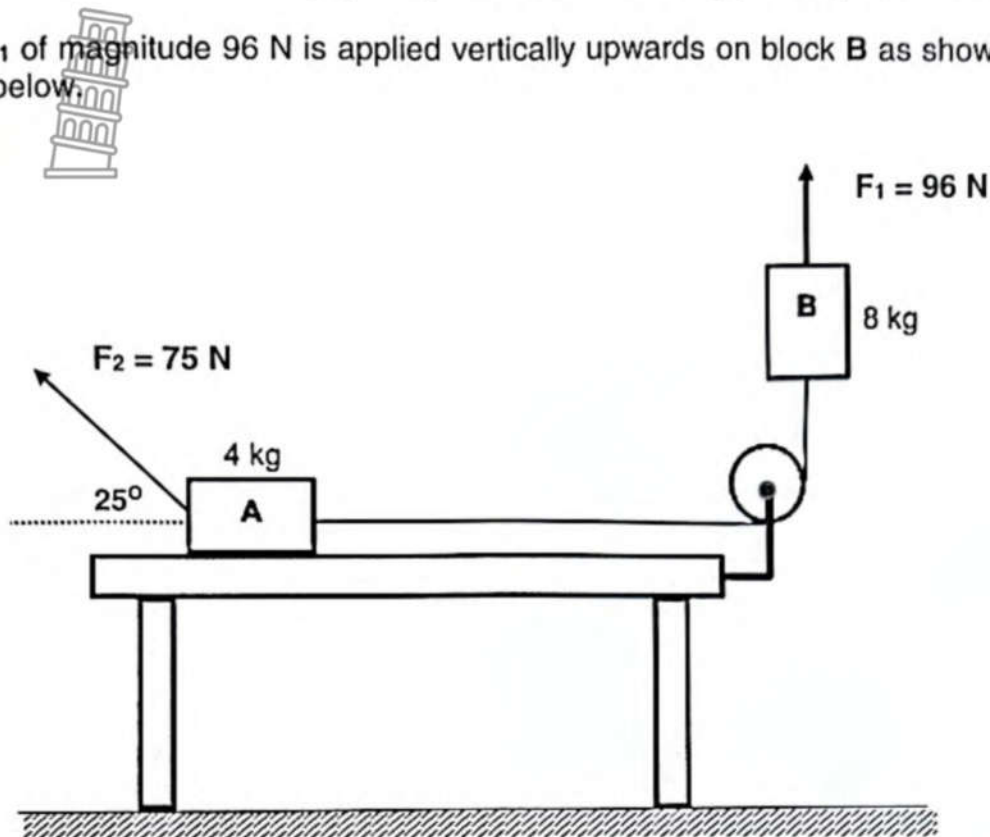

A force  $F_2$  of magnitude 75 N is now applied at an angle of  $25^\circ$  with the horizontal on block **A** and the block accelerates to the left. The kinetic frictional force on block **A** is 11,76 N. Ignore the effects of air friction.

- 2.1 State Newton's Second Law of Motion in words. (2)
- 2.2 Draw a labelled free-body diagram for block **A**. (5)
- 2.3 Calculate the magnitude of the:
  - 2.3.1 Acceleration of block **A** (5)
  - 2.3.2 Tension in the rope connected to block **A** (2)



[14]

**QUESTION 3 (Start on a new page.)**

The position-time graph for a ball thrown vertically downwards from the top of a 48 m high building is shown below. The ball bounces off the ground, reaching a maximum height of 8 m.

Ignore the effect of air resistance and the contact time with the ground. The graph is not drawn to scale.

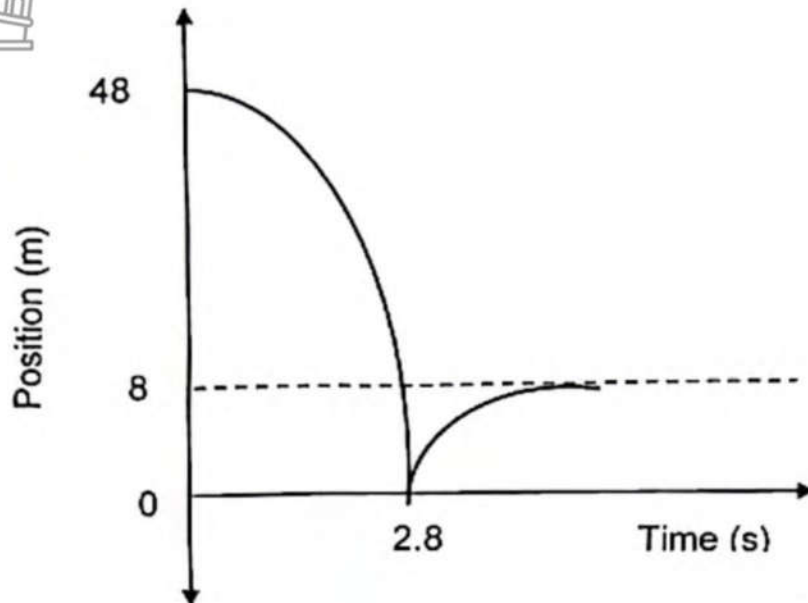

- 3.1 Explain what is meant by a *projectile*. (2)
- 3.2 Calculate the speed with which the ball:
- 3.2.1 is thrown downwards (4)
- 3.2.2 hits the ground (3)
- 3.2.3 bounces upwards from the ground (3)
- 3.3 Draw a velocity-time graph for the entire motion of the ball.

Indicate the following on your graph:

- (i) initial velocity with which the ball was thrown
- (ii) velocity with which the ball hits the ground
- (iii) time taken by the ball to hit the ground
- (iv) the velocity with which the ball bounces off the ground (4)



[16]

**QUESTION 4 (Start on a new page.)**

A tennis ball with a mass of 15,5 g strikes a stationary 8,45 kg block with a speed of  $45 \text{ m}\cdot\text{s}^{-1}$  and bounces straight back with a speed of  $10,60 \text{ m}\cdot\text{s}^{-1}$ . The block moves 1,32 m to the right as indicated in the diagram below.

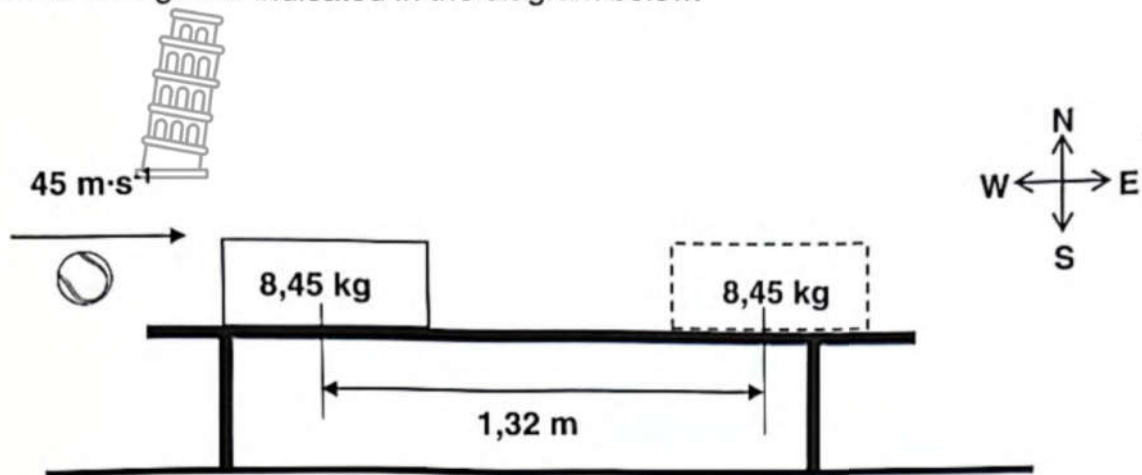

- 4.1 State the principle of conservation of linear momentum in words. (2)
- 4.2 Calculate the magnitude of the:
- 4.2.1 Velocity of the block immediately after collision (4)
- 4.2.2 Frictional force between the block and the table if the block moves  $1,32 \text{ m}$  before coming to rest (5)

[11]



**QUESTION 5 (Start on a new page.)**

A child with a mass 50 kg on a board mass 3 kg slides from rest down a sand dune. The sand dune has an angle of  $30^\circ$  with the horizontal and a height of 35 m. The coefficient of friction between the board and the sand is 0,45.

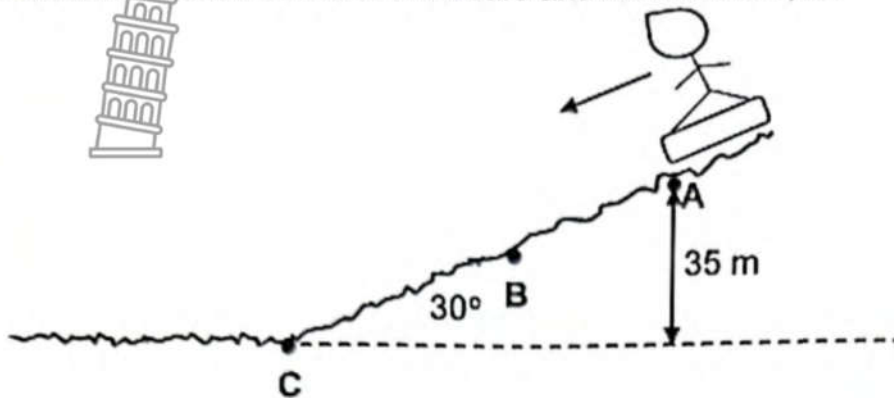

- 5.1 Define the term *non-conservative force*. (2)
- 5.2 Draw a labelled free-body diagram for the child and the board at point **B**. (3)
- 5.3 Calculate the frictional force that the child and the board experience as they slide down the sand dune. (3)
- 5.4 State the *work-energy theorem* in words. (2)
- 5.5 Calculate the final velocity that the child and board have when they reach point **B**. (5)

[15]



**QUESTION 6 (Start on a new page.)**

A siren of a stationary train emits sound waves of a constant frequency of 780 Hz. A person in a car with a detector accelerates constantly from rest at point X towards the train. Take the speed of sound in air as  $340 \text{ m}\cdot\text{s}^{-1}$ .

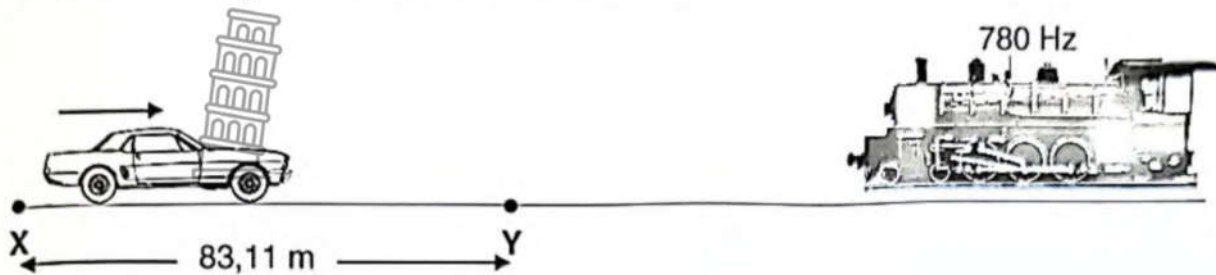

- 6.1 Name the phenomenon that was observed by the listener. (1)
- 6.2 Calculate the wavelength of the emitted sound waves. (2)
- 6.3 Explain why the observed frequency is higher than the emitted frequency. (2)

At point Y, 83,11 m from point X, the person in the car measures an observed frequency of 850 Hz.

- 6.4 Calculate the:
- 6.4.1 speed of the car at point Y (5)
- 6.4.2 acceleration of the car (3)

[13]





**QUESTION 7 (Start on a new page.)**

Sphere **N**, with charge  $-30 \mu\text{C}$ , is placed on an isolated stand. Sphere **M**, with charge  $-20 \mu\text{C}$  hangs on an inextensible string from a horizontal beam and is a distance of 80 cm from sphere **N** as shown in the diagram below.

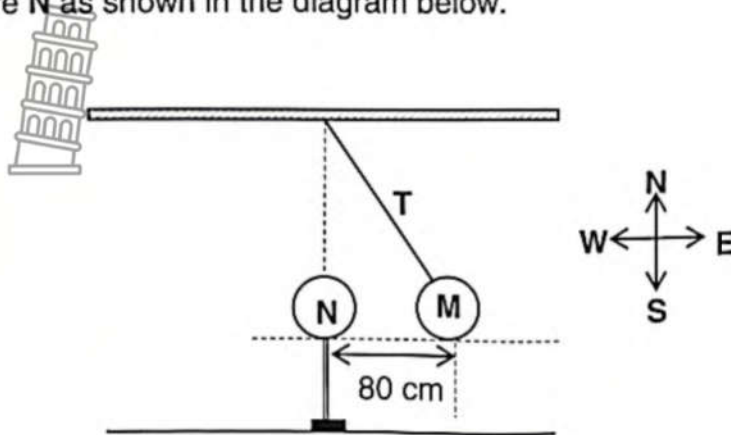

- 7.1 State Coulomb's Law in words. (2)
- 7.2 Draw a labelled free-body diagram for sphere **M**. (3)
- 7.3 Calculate the magnitude of the:
  - 7.3.1 electrostatic force between the two spheres (3)
  - 7.3.2 tension **T** in the string if the mass of sphere **M** is 90 g (4)

[12]



**QUESTION 8 (Start on a new page.)**

Two small spheres, **A** with a charge of  $+5 \text{ nC}$  and **B** with a charge of  $-4 \text{ nC}$  respectively, are placed a certain distance from each other in a vacuum as shown in the diagram below.



8.1 Define the term *electric field* in words. (2)

8.2 Draw the electric field pattern between spheres **A** and **B**. (3)

**P** is a point LEFT of spheres **A** and **B**. Point **P** is at a distance  $r$  from sphere **A** and sphere **A** is at a distance  $3r$  from sphere **B** as shown in the diagram below. The net electric field at point **P** is  $4128 \text{ N}\cdot\text{C}^{-1}$  west.

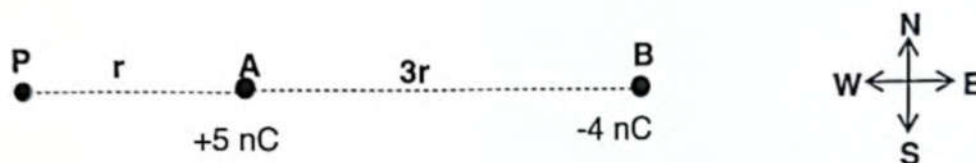

8.3 Calculate the value of  $r$ . (6)  
[11]



**QUESTION 9 (Start on a new page.)**

A battery with an internal resistance of  $0,5 \Omega$  and emf ( $\epsilon$ ) of  $24 \text{ V}$  is connected to four resistors, a closed switch, a high resistance voltmeter ( $V$ ) with  $22,3 \text{ V}$  and ammeter of negligible resistance, as shown in the diagram below.

The resistance of the connecting wires must be ignored.

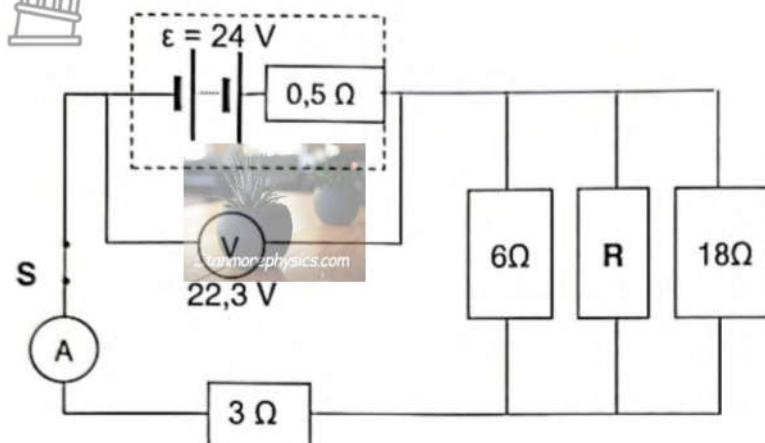

- 9.1 Explain the term *emf of 24 V* with reference to work done. (2)
- 9.2 Calculate the:
  - 9.2.1 Current in the  $3 \Omega$  resistor (3)
  - 9.2.2 Power dissipated in the  $18 \Omega$  resistor (5)
  - 9.2.3 Current in resistor  $R$  (4)

Resistor  $R$  is removed from the circuit.

- 9.3 Will the power dissipated in the  $18 \Omega$  resistor INCREASE, DECREASE or REMAIN THE SAME? Explain the answer. (3)

[17]



**QUESTION 10 (Start on a new page.)**

The simplified diagram below represents an alternating current (AC) generator.

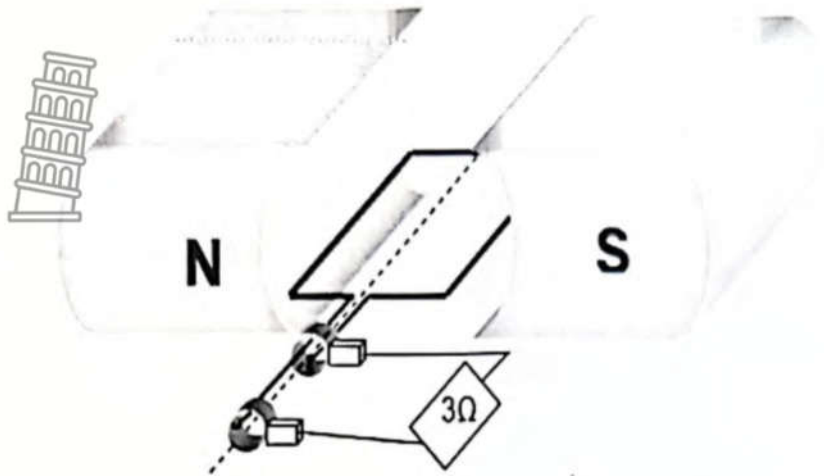

- 10.1 Write down the energy conversion that occurs in an AC generator. (2)
- 10.2 Which structural change must be done to the components of the AC generator to change it into a DC generator? (1)
- A  $3\ \Omega$  resistor is connected to the AC generator.
- 10.3 Calculate the maximum current that flows through the resistor if the resistor has an average power of 100 W. (5)

**[8]**

**QUESTION 11 (Start on a new page.)**

Learners conduct an experiment to investigate the photoelectric effect. Metal disc **M** is irradiated with three light sources of different wavelengths and the results obtained are noted in the table below.

Light source	Wavelength ( $\times 10^{-9}$ m)	Emission of photoelectrons
<b>A</b>	480	Photoelectrons emitted that move away from metal
<b>B</b>	620	No photoelectrons emitted
<b>C</b>	570	Photoelectrons emitted and do NOT move away from metal

- 11.1 Define the term *work function* in words. (2)
- 11.2 Explain why light source **A** releases photoelectrons from the metal disc **M**, but not light source **B**. (2)
- 11.3 Calculate the:
- 11.3.1 Work function of metal **M** (3)
- 11.3.2 Speed with which the photoelectrons are moving if metal disc **M** is irradiated with light source **A** (5)
- 11.4 Light source **A** is BLUE light and light source **B** is ORANGE light. Which colour of light is light source **C**? Choose between VIOLET, GREEN or RED. (1)

[13]

**TOTAL:150**





Downloaded from [Stanmorephysics.com](http://Stanmorephysics.com)

DATA FOR PHYSICAL SCIENCES GRADE 12  
PAPER 1 (PHYSICS)

GEGEWENS VIR FISIESTE WETENSAPPE GRAAD 12  
VRAESTEL 1 (FISIKA)

TABLE 1: PHYSICAL CONSTANTS/TABEL 1: FISIESTE KONSTANTES

NAME/NAAM	SYMBOL/SIMBOOL	VALUE/WAARDE
Acceleration due to gravity <i>Swaartekragversnelling</i>	g	9,8 m·s <sup>-2</sup>
Universal gravitational constant <i>Universele gravitasiekonstant</i>	G	6,67 x 10 <sup>-11</sup> N·m <sup>2</sup> ·kg <sup>-2</sup>
Speed of light in a vacuum <i>Spoed van lig in 'n vakuum</i>	c	3,0 x 10 <sup>8</sup> m·s <sup>-1</sup>
Planck's constant <i>Planck se konstante</i>	h	6,63 x 10 <sup>-34</sup> J·s
Coulomb's constant <i>Coulomb se konstante</i>	k	9,0 x 10 <sup>9</sup> N·m <sup>2</sup> ·C <sup>-2</sup>
Charge on electron <i>Lading op elektron</i>	e	1,6 x 10 <sup>-19</sup> C
Electron mass <i>Elektronmassa</i>	m <sub>e</sub>	9,11 x 10 <sup>-31</sup> kg
Mass of the Earth <i>Massa van die Aarde</i>	M	5,98 x 10 <sup>24</sup> kg
Radius of the Earth <i>Radius van die Aarde</i>	R <sub>E</sub>	6,38 x 10 <sup>6</sup> m



TABLE 2: FORMULAE/TABEL 2: FORMULES

## MOTION/BEWEGING

$v_f = v_i + a \Delta t$	$\Delta x = v_i \Delta t + \frac{1}{2} a \Delta t^2$ or/of $\Delta y = v_i \Delta t + \frac{1}{2} a \Delta t^2$
$v_f^2 = v_i^2 + 2a\Delta x$ or/of $v_f^2 = v_i^2 + 2a\Delta y$	$\Delta x = \left( \frac{v_i + v_f}{2} \right) \Delta t$ or/of $\Delta y = \left( \frac{v_i + v_f}{2} \right) \Delta t$

## FORCE/KRAG

$F_{\text{net}} = ma$	$p = mv$
$f_s^{\text{max}} = \mu_s N$	$f_k = \mu_k N$
$F_{\text{net}} \Delta t = \Delta p$ $\Delta p = mv_f - mv_i$	$w = mg$
$F = G \frac{m_1 m_2}{d^2}$ or/of $F = G \frac{m_1 m_2}{r^2}$	$g = G \frac{M}{d^2}$ or/of $g = G \frac{M}{r^2}$

## WORK, ENERGY AND POWER/ARBEID, ENERGIE EN DRYWING

$W = F \Delta x \cos \theta$	$U = mgh$ or/of $E_p = mgh$
$K = \frac{1}{2} mv^2$ or/of $E_k = \frac{1}{2} mv^2$	$W_{\text{net}} = \Delta K$ or/of $W_{\text{net}} = \Delta E_k$ $\Delta K = K_f - K_i$ or/of $\Delta E_k = E_{kf} - E_{ki}$
$W_{\text{nc}} = \Delta K + \Delta U$ or/of $W_{\text{nc}} = \Delta E_k + \Delta E_p$	$P = \frac{W}{\Delta t}$
$P_{\text{ave}} = F v_{\text{ave}}$ / $P_{\text{gemid}} = F v_{\text{gemid}}$	

## WAVES, SOUND AND LIGHT/GOLWE, KLANK EN LIG

$v = f \lambda$	$T = \frac{1}{f}$
$f_L = \frac{v \pm v_L}{v \pm v_s} f_s$ or/of $f_L = \frac{v \pm v_L}{v \pm v_b} f_b$	$E = hf$ or/of $E = h \nu$
$E = W_0 + E_{k(\text{max})}$ or/of $E = W_0 + K_{\text{max}}$ where/waar $E = hf$ and/en $W_0 = hf_0$ and/en $E_{k(\text{max})} = \frac{1}{2} mv_{\text{max}}^2$ or/of $K_{\text{max}} = \frac{1}{2} mv_{\text{max}}^2$	

**ELECTROSTATICS/ELEKTROSTATIKA**

$F = \frac{kQ_1Q_2}{r^2}$	$E = \frac{kQ}{r^2}$
$V = \frac{W}{q}$	$E = \frac{F}{q}$
$n = \frac{Q}{e}$ or/of $n = \frac{Q}{q_e}$	

**ELECTRIC CIRCUITS/ELEKTRIESE STROOMBANE**

$R = \frac{V}{I}$	$\text{emf } (\mathcal{E}) = I(R + r)$ $\text{emk } (\mathcal{E}) = I(R + r)$
$R_s = R_1 + R_2 + \dots$ $\frac{1}{R_p} = \frac{1}{R_1} + \frac{1}{R_2} + \dots$	$q = I \Delta t$
$W = Vq$ $W = VI \Delta t$ $W = I^2 R \Delta t$ $W = \frac{V^2 \Delta t}{R}$	$P = \frac{W}{\Delta t}$ $P = VI$ $P = I^2 R$ $P = \frac{V^2}{R}$

**ALTERNATING CURRENT/WISSELSTROOM**

$I_{\text{rms}} = \frac{I_{\text{max}}}{\sqrt{2}}$ / $I_{\text{wgk}} = \frac{I_{\text{maks}}}{\sqrt{2}}$	$P_{\text{ave}} = V_{\text{rms}} I_{\text{rms}}$ / $P_{\text{gemiddeld}} = V_{\text{wgk}} I_{\text{wgk}}$
$V_{\text{rms}} = \frac{V_{\text{max}}}{\sqrt{2}}$ / $V_{\text{wgk}} = \frac{V_{\text{maks}}}{\sqrt{2}}$	$P_{\text{ave}} = I_{\text{rms}}^2 R$ / $P_{\text{gemiddeld}} = I_{\text{wgk}}^2 R$
	$P_{\text{ave}} = \frac{V_{\text{rms}}^2}{R}$ / $P_{\text{gemiddeld}} = \frac{V_{\text{wgk}}^2}{R}$



# education

DEPARTMENT: EDUCATION  
MPUMALANGA PROVINCE

**NATIONAL  
SENIOR CERTIFICATE  
NASIONALE  
SENIOR SERTIFIKAAT**

**GRADE/GRAAD 12**

**PHYSICAL SCIENCES: PHYSICS (P1)  
FISIESE WETENSKAPPE: FISIKA (V1)**

**SEPTEMBER 2023**

**MARKING GUIDELINES/NASIENRIGLYNE**

**MARKS/PUNTE: 150**

**These marking guideline consists of 14 pages**

***Hierdie nasienriglyne bestaan uit 14 bladsye***



**QUESTION 1 / VRAAG 1**

- 1.1 C ✓✓ (2)
- 1.2 C ✓✓ (2)
- 1.3 A ✓✓ (2)
- 1.4 B ✓✓ (2)
- 1.5 D ✓✓ (2)
- 1.6 A ✓✓ (2)
- 1.7 B ✓✓ (2)
- 1.8 C ✓✓ (2)
- 1.9 B ✓✓ (2)
- 1.10 D ✓✓ (2)



**[20]**



**QUESTION 2 / VRAAG 2**

2.1

**Marking criteria/Nasienkriteria**

If any one of the underlined key words/phrases in the **correct context** is omitted, deduct 1 mark. /Indien enige van die onderstreepte sleutelwoorde/frases in die **korrekte konteks** uitgelaat is, trek 1 punt af.

When a net force acts on an object, the object will accelerate in the direction of the force and the acceleration is directly proportional to the resultant/net force and inversely proportional to the mass of the object. ✓✓

Wanneer 'n resulterende/netto krag op 'n voorwerp inwerk, versnel die voorwerp in die rigting van die krag teen 'n versnelling direk eweredig aan die resultante/netto krag en omgekeerd eweredig aan die massa van die voorwerp.

**OR/OF**

The resultant/net force acting on an object is equal to the rate of change of momentum of the object. **(2 or 0)**

Die resulterende/netto krag wat op 'n voorwerp inwerk is gelyk aan die tempo van verandering van momentum. **(2 of 0)**

(2)

2.2

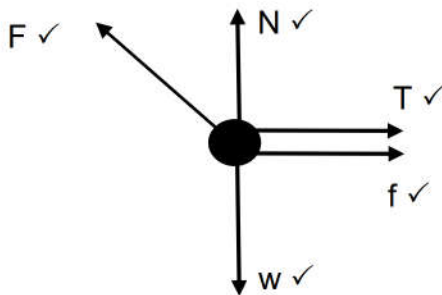

(5)

**Accepted labels / Aanvaarde benoemings**

w	$F_g / F_w$ / force of earth on block / weight / mg / gravitational force / VALUE
F	$F_{\text{applied}} / F_A$ / Applied force
T	Tension in rope / $F_T$
F	$F_{\text{friction}} / F_f$ / frictional force /
N	Normal force / $F_N$

**Notes/Aantekeninge:**

- Mark awarded for label and arrow.
- Any additional forces: deduct 1 mark: max  $\frac{4}{5}$
- No labels: deduct 1 mark: max  $\frac{4}{5}$
- If everything correct, but no arrows: deduct 1 mark:  $\frac{4}{5}$
- Force(s) not touching object: deduct 1 mark: max  $\frac{4}{5}$
- Ignore relative sizes of the vectors



2.3.1 **Marking criteria/Nasienkriteria:**

- Formula for block A or block B ✓
- Substitution of Fnet for block A ✓
- Substitution of Fnet for block B ✓
- 8a **OR** 4a ✓
- Answer ✓

For Block A: $F_{net} = ma$ $F_x + (-T) + (-f) = ma$ $(75)\cos 25 - T - 11,76 \checkmark = 4a \checkmark$ $56,21 - T = 4a$ $T = -4a + 56,21$	} Any one ✓	For Block B: $F_{net} = ma$ $F_g + T + (-F) = ma$ $78,4 + T - 96 \checkmark = 8a$ $T - 17,6 = 8a$ $T = 8a + 17,6$
$\therefore -4a + 56,21 = 8a + 17,6$ $12a = 38,61$ $a = 3,22 \text{ m}\cdot\text{s}^{-2} \checkmark$		

(5)

2.3.2 **POSITIVE MARKING FROM QUESTION 2.3.1**

**Marking criteria/Nasienkriteria:**

- Substitution to calculate T ✓
- Answer ✓

For Block A: $T = -4a + 56,21$ $= (-4)(3,22) + 56,21 \checkmark$ $= 43,33 \text{ N} \checkmark$	For Block B: $T = 8a + 17,6$ $= (8)(3,22) + 17,6$ $= 43,36 \text{ N}$
--	--

(2)

[14]

**QUESTION 3 / VRAAG 3**

3.1 An object which has been given an initial velocity and then it moves under the influence of the gravitational force only. ✓ ✓ **(2 or 0)**

'n Voorwerp waaraan 'n beginsnelheid gegee is en wat dan slegs onder die invloed van die gravitasiekrag beweeg. **(2 or 0)**

(2)

3.2.1

<b>Upwards positive/ Opwaarts positief:</b> $\Delta y = v_i \Delta t + \frac{1}{2} a \Delta t^2 \checkmark$ $-48 \checkmark = v_i(2,8) + \frac{1}{2} (-9,8)(2,8)^2 \checkmark$ $v_i = -3,42$ $v_i = 3,42 \text{ m}\cdot\text{s}^{-1} \checkmark$	<b>Downwards positive/ Afwaarts positief:</b> $\Delta y = v_i \Delta t + \frac{1}{2} a \Delta t^2 \checkmark$ $48 \checkmark = v_i(2,8) + \frac{1}{2} (9,8)(2,8)^2 \checkmark$ $v_i = 3,42 \text{ m}\cdot\text{s}^{-1} \checkmark$
--	---

(4)

3.2.2

**POSITIVE MARKING FROM QUESTION 3.2.1**  
**POSITIEWE NASIEN VANAF VRAAG 3.2.1**

<p><b>OPTION 1</b> <b>Upwards Positive/ Opwaarts positief</b> <math>v_f = v_i + a \Delta t \checkmark</math> <math>v_f = -3,42 + (-9,8)(2,8) \checkmark</math> <math>v_f = -30,86 \text{ m}\cdot\text{s}^{-1}</math> <math>v_f = 30,86 \text{ m}\cdot\text{s}^{-1} \checkmark</math></p>	<p><b>Downwards Positive/ Afwaarts positief</b> <math>v_f = v_i + a \Delta t \checkmark</math> <math>v_f = 3,42 + (9,8)(2,8) \checkmark</math> <math>v_f = 30,86 \text{ m}\cdot\text{s}^{-1} \checkmark</math></p>
<p><b>OPTION 2</b> <b>Upwards Positive/ Opwaarts positief</b> <math>v_f^2 = v_i^2 + 2a \Delta y \checkmark</math> <math>v_f^2 = (-3,42)^2 + 2(-9,8)(-48) \checkmark</math> <math>v_f = 30,86 \text{ m}\cdot\text{s}^{-1} \checkmark</math></p>	<p><b>Downwards Positive/ Afwaarts positief</b> <math>v_f^2 = v_i^2 + 2a \Delta y \checkmark</math> <math>v_f^2 = (3,42)^2 + 2(9,8)(48) \checkmark</math> <math>v_f = 30,86 \text{ m}\cdot\text{s}^{-1} \checkmark</math></p>
<p><b>OPTION 3</b> <b>Upwards Positive/ Opwaarts positief</b> <math>\Delta x = \frac{(v_f + v_i)}{2} \Delta t \checkmark</math> <math>-48 = \frac{(v_f - 3,42)}{2} 2,8 \checkmark</math> <math>v_f = -30,87 \text{ m}\cdot\text{s}^{-1}</math> <math>v_f = 30,87 \text{ m}\cdot\text{s}^{-1} \checkmark</math></p>	<p><b>Downwards Positive/ Afwaarts positief</b> <math>\frac{(v_f + v_i)}{2} \Delta t \checkmark</math> <math>48 = \frac{(v_f + 3,42)}{2} 2,8 \checkmark</math> <math>v_f = 30,87 \text{ m}\cdot\text{s}^{-1} \checkmark</math></p>
<p><b>OPTION 4</b> <math>(E_m)_A = (E_m)_B</math> <math>(mgh + \frac{1}{2}mv^2)_A = (mgh + \frac{1}{2}mv^2)_B</math> } Any one <math>\checkmark</math> Enige een <math>\frac{m(9,8)(48) + \frac{1}{2}m(3,42)^2}{v} = 0 + \frac{1}{2}mv^2 \checkmark</math> <math>v = 30,86 \text{ m}\cdot\text{s}^{-1} \checkmark</math></p>	
<p><b>OPTION 5</b> <math>F_{\text{net}} \Delta t = \Delta p</math> <math>F_{\text{net}} \Delta t = mv_f - mv_i</math> <math>mg \Delta t = mv_f - mv_i</math> <math>g \Delta t = v_f - v_i</math> <math>(9,8)(2,9) = v_f - 3,42 \checkmark</math> <math>v = 30,86 \text{ m}\cdot\text{s}^{-1} \checkmark</math> } Any one <math>\checkmark</math> Enige een</p>	

(3)

3.2.3

<p><b>Upwards positive / Opwaarts positief</b> <math>v_f^2 = v_i^2 + 2a \Delta y \checkmark</math> <math>0 = v_i^2 + 2(-9,8)(8) \checkmark</math> <math>v_i = 12,52 \text{ m}\cdot\text{s}^{-1} \checkmark</math></p>	<p><b>Downwards positive/ Afwaarts positief</b> <math>v_f^2 = v_i^2 + 2a \Delta y \checkmark</math> <math>0 = v_i^2 + 2(9,8)(-8) \checkmark</math> <math>v_i = 12,52 \text{ m}\cdot\text{s}^{-1} \checkmark</math></p>
---	--

(3)



3.3

**Marking criteria/Nasienkriteria:**

- Initial velocity with which the ball was thrown (3.2.1) ✓
- Beginsnelheid waarmee bal gegooi is
- Final velocity with which the ball hit the ground (3.2.2) ✓
- Eindsnelheid waarmee die bal die grond tref
- Time taken to hit the ground (2,8 s) ✓
- Tyd om die grond te tref (2,8 s)
- The velocity with which the ball bounces off the ground – line parallel to other line (3.2.3) ✓
- Die snelheid waarmee die bal van die grond as bons – lyn parallel met ander lyn

**POSITIVE MARKING FROM/POSITIEWE MERK VANAF 3.2.1., 3.2.2 & 3.2.3  
UPWARDS POSITIVE/OPWAARTS POSITIEF**

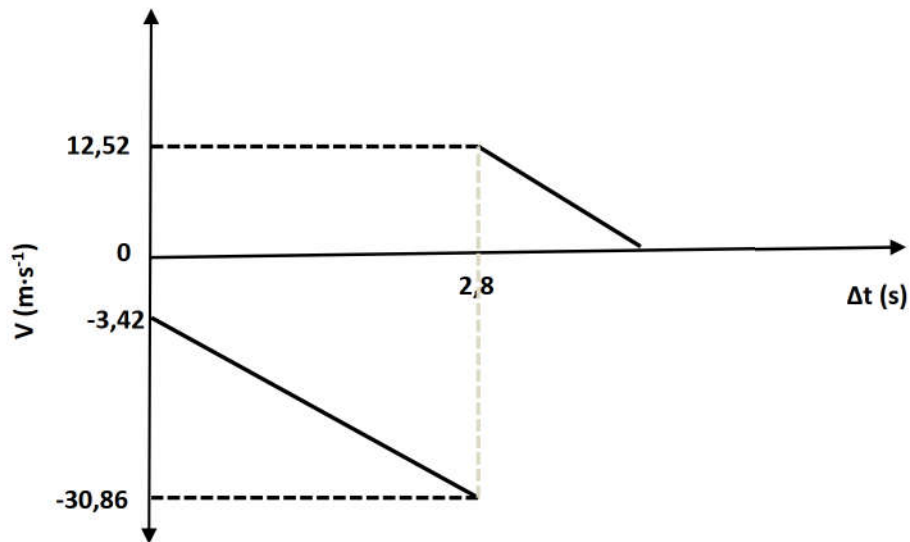

**DOWNWARDS POSITIVE/AFWAARTS POSITIEF**

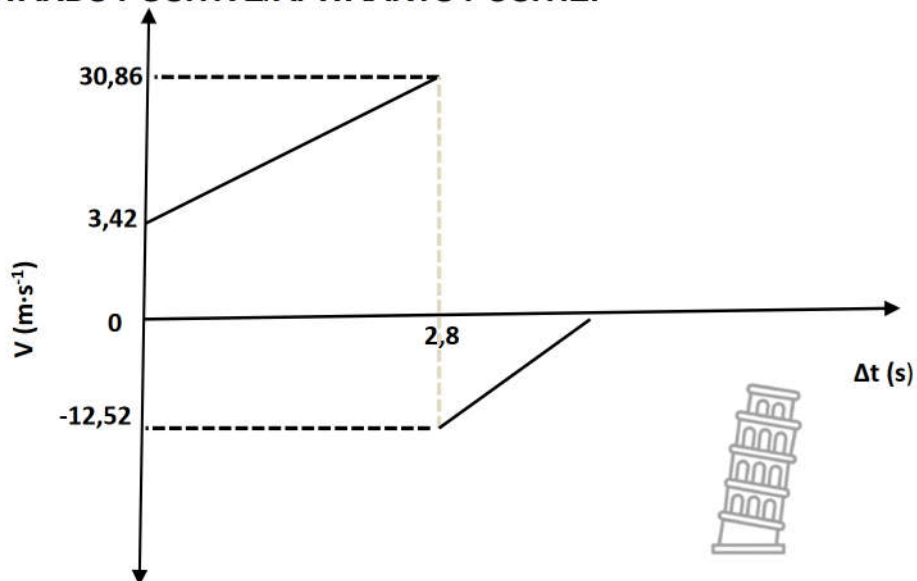

(4)  
[16]

**QUESTION 4 / VRAAG 4**

4.1

**Marking criteria/Nasienkriteria**

If any one of the underlined key words/phrases in the **correct context** is omitted, deduct 1 mark. /Indien enige van die onderstreepte sleutelwoorde/frases in die **korrekte konteks** uitgelaat is, trek 1 punt af.

The total (linear) momentum of an isolated/closed system remains constant/is conserved. ✓✓

Die totale (lineêre) momentum in 'n geïsoleerde sisteem bly konstant/behoue. ✓✓



(2)

4.2.1

**TAKE TO THE LEFT AS POSITIVE/NEEM LINKS AS POSITIEF**

$$\left. \begin{aligned} \Sigma p_i &= \Sigma p_f \\ (mv_i)_1 + (mv_i)_2 &= (mv_f)_1 + (mv_f)_2 \end{aligned} \right\} \checkmark \text{ Any one/enige een}$$

$$(0,015)(-45) + (8,45)(0) \checkmark = (0,015)(10,60) + (8,45)(v_f) \checkmark$$

$$v = -0,10 \text{ m}\cdot\text{s}^{-1}$$

$$v = 0,10 \text{ m}\cdot\text{s}^{-1} \checkmark$$

**TAKE TO THE RIGHT AS POSITIVE/NEEM REGS AS POSITIEF**

$$\left. \begin{aligned} \Sigma p_i &= \Sigma p_f \\ (mv_i)_1 + (mv_i)_2 &= (mv_f)_1 + (mv_f)_2 \end{aligned} \right\} \checkmark \text{ Any one/enige een}$$

$$(0,015)(45) + (8,45)(0) \checkmark = (0,015)(-10,60) + (8,45)(v_f) \checkmark$$

$$v = 0,10 \text{ m}\cdot\text{s}^{-1} \checkmark$$

(4)

4.2.2

**POSITIVE MARKING FROM QUESTION 4.2.1**

**OPTION 1**

$$v_f^2 = v_i^2 + 2a \Delta y$$

$$0^2 \checkmark = (0,10)^2 + 2(a)(1,32) \checkmark$$

$$a = -0,00378 \text{ m}\cdot\text{s}^{-2} \quad (a = -3,79 \times 10^{-3} \text{ m}\cdot\text{s}^{-2})$$

$$F_{\text{net}} = ma \checkmark$$

$$f = (8,45)(-0,00378) \checkmark$$

$$f = 0,03 \text{ N} \checkmark$$

**POSITIVE MARKING FROM QUESTION 4.2.1**

**OPTION 2**

$$v_f^2 = v_i^2 + 2a \Delta y$$

$$0^2 = (0,10)^2 + 2(a)(1,32) \checkmark$$

$$a = -0,00378 \text{ m}\cdot\text{s}^{-2} \quad (a = -3,79 \times 10^{-3} \text{ m}\cdot\text{s}^{-2})$$

$$v_f = v_i + a \Delta t$$

$$0 = 0,10 + (-0,00378) \Delta t$$

$$\Delta t = 26,39 \text{ s} \checkmark$$

$$F_{\text{net}} \Delta t = mv_f - mv_i \checkmark$$

$$f(26,39) = (8,45)(0) - (8,45)(0,10) \checkmark$$

$$f = -0,03 \text{ N}$$

$$f = 0,03 \text{ N} \checkmark$$



(5)  
[11]



**QUESTION 5 / VRAAG 5**

5.1

**Marking criteria/Nasienkriteria**  
 If any one of the underlined key words/phrases in the **correct context** is omitted, deduct 1 mark. /Indien enige van die onderstreepte sleutelwoorde/frases in die **korrekte konteks** uitgelaat is, trek 1 punt af.

A force for which the work done in moving an object between two points depends on the path taken ✓✓

'n Krag waarvoor die arbeid verrig om 'n voorwerp tussen twee punte te beweeg, afhanglik is van die roete wat gevolg word. (2)

5.2

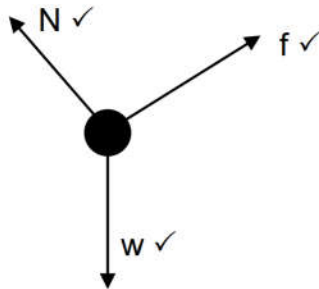

Accepted labels / Aanvaarde benoemings	
w	$F_g / F_w$ / force of earth on block / weight / mg / gravitational force /
f	$F_{\text{friction}} / F_f$ / frictional force
N	Normal force / $F_N$

5.3

$f_k = \mu_k N \checkmark$ $= (0,45)(449,81) \checkmark$ $= 202,42 \text{ N} \checkmark$	$N = F_{g\perp}$ $= (53)(9,8)\cos 30^\circ$ $= 449,81 \text{ N}$
--	--

5.4

**Marking criteria/Nasienkriteria**  
 If any one of the underlined key words/phrases in the **correct context** is omitted, deduct 1 mark. /Indien enige van die onderstreepte sleutelwoorde/frases in die **korrekte konteks** uitgelaat is, trek 1 punt af.

The net work done on an object is equal to the change in kinetic energy of the object. ✓✓

Die netto arbeid verrig op 'n voorwerp is gelyk aan die verandering in kinetiese energie van die voorwerp **OF** die arbeid verrig op die voorwerp deur 'n netto krag is gelyk aan die verandering in kinetiese energie van die voorwerp. (2)

5.5

**POSITIVE MARKING FROM Q5.3**

**OPTION 1**

$W_{\text{net}} = \Delta E_k$ $f\Delta x \cos \theta + N\Delta x \cos \theta + F_g \Delta x \cos \theta = \frac{1}{2}mv_f^2 - \frac{1}{2}mv_i^2$ $(202,42)(35)\cos 180^\circ + 0 + (53)(9,8)(35)\cos 60^\circ \checkmark = \frac{1}{2}(53)v_f^2 \checkmark - 0$ $v_f = 8,70 \text{ m}\cdot\text{s}^{-1} \checkmark$	 } Any one ✓
--	-----------------

**OPTION 2**

$$W_{nc} = \Delta E_k + \Delta E_p$$

$$f \Delta x \cos \theta = [\frac{1}{2} m v_f^2 - \frac{1}{2} m v_i^2] + [mgh_f - mgh_i]$$

$$(202,42)(35) \cos 180^\circ = [\frac{1}{2}(53) v_f^2 - 0] + [(53)(9,8)(17,5) - (53)(9,8)(35)]$$

$$v_f = 8,70 \text{ m}\cdot\text{s}^{-1}$$

} Any one ✓

(5)  
[15]



**QUESTION 6 / VRAAG 6**

6.1 Doppler effect / effek ✓

(1)

6.2

$$v = f \lambda$$

$$340 = 780 \lambda$$

$$\lambda = 0,44 \text{ m}$$

(2)

6.3 Waves in front of source are more compact/ wavelength decreases ✓  
More waves per second reaches the listener ✓

Golwe voor die bron is meer kompak/ golflengte neem af  
Meer golwe per sekonde bereik die luisteraar

(2)

6.4.1

$$f_L = \frac{v \pm v_L}{v \pm v_S} f_S \quad \text{OR} \quad f_L = \frac{v}{v - v_S} f_S$$

$$850 = \left( \frac{340 + v_L}{340 + 0} \right) 780$$

$$v_L = 30,51 \text{ m}\cdot\text{s}^{-1}$$

(5)

6.4.2

$$v_f^2 = v_i^2 + 2a \Delta y$$

$$(30,51)^2 = 0^2 + 2a(83,11)$$

$$a = 5,60 \text{ m}\cdot\text{s}^{-2}$$

(3)  
[13]



**QUESTION 7 / VRAAG 7**

7.1

**Marking criteria/Nasienkriteria**  
 If any one of the underlined key words/phrases in the **correct context** is omitted, deduct 1 mark. /Indien enige van die onderstreepte sleutelwoorde/frases in die **korrekte konteks** uitgelaat is, trek 1 punt af.

**Note: If masses used ( 0/2 )**

The magnitude of the electrostatic force exerted by one point charge ( $Q_1$ ) on another point charge ( $Q_2$ ) is directly proportional to the product of the magnitudes of the charges ✓ and inversely proportional to the square of the distance ( $r$ ) between them ✓

Die grootte van die elektrostatiese krag wat een puntlading ( $Q_1$ ) op 'n ander puntlading ( $Q_2$ ) uitoefen, is direk eweredig aan die produk van die groottes van die ladings ✓ en omgekeerd eweredig aan die kwadraat van die afstand ( $r$ ) tussen hulle. ✓

(2)

7.2

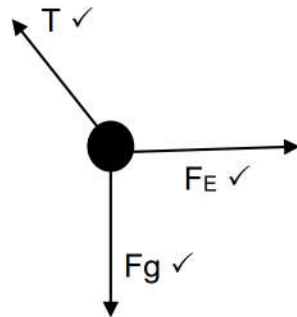

Accepted labels / Aanvaarde benoemings	
W	$F_g$ / $F_w$ / force of earth on block / weight / $mg$ / gravitational force / 0,392 N
$F_E$	Electrostatic force
T	Tension in rope / $F_T$

(3)

Notes/Aantekeninge:

- Any additional forces: deduct 1 mark: max  $2/3$
- No labels: deduct 1 mark: max  $2/3$
- No arrows:  $0/3$
- Force(s) not touching object: deduct 1 mark: max  $2/3$
- Ignore relative sizes of the vectors





7.3.1 
$$F = \frac{kQ_1Q_2}{r^2} \checkmark$$

$$= \frac{(9 \times 10^9)(30 \times 10^{-6})(20 \times 10^{-6})}{(0,8)^2} \checkmark$$

$$F = 8,44 \text{ N} \checkmark \quad (8,4375 \text{ N})$$

7.3.2 
$$F_g = mg$$

$$= (0,09)(9,8)$$

$$= 0,882 \text{ N} \checkmark$$

$$T^2 = F_e^2 + F_g^2 \checkmark$$

$$= (8,44)^2 + (0,88)^2 \checkmark$$

$$T = 8,49 \text{ N} \checkmark$$

(3)

(4)

[12]

**QUESTION 8 / VRAAG 8**

8.1 **Marking criteria/Nasienriglyne:**  
 -1 mark for each of the 3 key words omitted in the correct context.  
 -1 punt vir elk van die 3 sleutelwoorde weggelaat in die korrekte konteks.  
 The electric field is an area in space where an electric charge experiences a force. ✓✓  
 Die elektriese veld is 'n gebied in die ruimte waarin 'n elektriese lading 'n krag ondervind

(2)

8.2

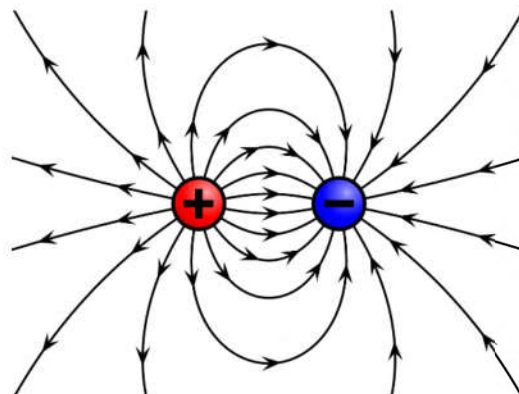

Criteria for sketch/Kriteria vir skets	Marks/Punte
Correct shape as shown. Korrekte vorm soos getoon.	✓
Direction away from positive to negative. Rigting weg van positief na negatief.	✓
Field lines start on spheres and do not cross for correct diagram. Veldlyne begin op elke sfeer en kruis nie vir korrekte diagram.	✓

(3)

8.3

$$E_{\text{nett}} = E_1 + E_2$$

$$E_{\text{net}} = \frac{kQ}{r^2} - \frac{kQ}{r^2} \quad \text{(Mark for/Punt vir } \frac{kQ}{r^2} \text{)}$$

$$\checkmark 4\,128 = \frac{(9 \times 10^9)(5 \times 10^{-9})}{r^2} \checkmark - \checkmark \frac{(9 \times 10^9)(4 \times 10^{-9})}{(4r)^2} \checkmark$$

$$4\,128 = \frac{45}{r^2} - \frac{36}{16r^2}$$

$$r = 0,10 \text{ m} \checkmark$$

(6)  
[11]

**QUESTION 9 / VRAAG 9**

9.1 24 Joule ✓ per unit coulomb charge work done. ✓

Arbeid van 24 Joule per eenheid coulomb lading (2)

9.2.1

$$r_i = \frac{\text{lost } V}{I} \checkmark$$

$$I = \frac{24 - 22,3}{0,5} \checkmark$$

$$= 3,4 \text{ A} \checkmark$$

(3)

9.2.2

**POSITIVE MARKING FROM Q9.2.1**

$$V_{3\Omega} = IR$$

$$= 3,4(3) \checkmark$$

$$= 10,2 \text{ V}$$

$$V_{18\Omega} = \frac{V^2}{R} \checkmark$$

$$P_{18\Omega} = \frac{(12,1)^2}{18} \checkmark$$

$$= 8,314 \text{ W} \checkmark$$

$$V_{\parallel} = 22,3 - 10,2 \checkmark$$

$$= 12,1 \text{ V}$$

(5)

9.2.3

**POSITIVE MARKING FROM Q9.2.1 & Q9.2.2**

$$I_{6\Omega} = \frac{V}{R} \checkmark$$

$$= \frac{12,1}{6} \checkmark$$

$$= 2,02 \text{ A}$$

$$I_{18\Omega} = \frac{V}{R}$$

$$= \frac{12,1}{18} \checkmark$$

$$= 0,67 \text{ A}$$

$$I_R = I_{\text{tot}} - I_{6\Omega} - I_{18\Omega}$$

$$= 3,4 - 2,02 - 0,67$$

$$= 0,71 \text{ A} \checkmark$$



(4)



- 9.3 Increase ✓  
 R (18Ω) remains constant,  $V_{||}$  increases ✓  
 Current in circuit decreases  
 $P = \frac{V^2}{R}$  ✓

(3)  
 [17]



**QUESTION 10 / VRAAG 10**

- 10.1 Kinetic/mechanical energy TO electrical energy ✓✓  
*Kinetiese/meganiese energie NA elektriese energie*

(2)

- 10.2 Slip rings (AC) and split rings (DC) ✓  
 Sleepringe (WS) en splitringe (GS)

(1)

10.3

<b>OPTION 1</b>	<b>OPTION 2</b>
$P_{ave} = I_{rms}^2 R$ ✓ $100 = I_{rms}^2 (3)$ ✓ $I_{rms} = 5,77A$  $I_{rms} = \frac{I_{max}}{\sqrt{2}}$ ✓ $5,77 = \frac{I_{max}}{\sqrt{2}}$ ✓ $I_{max} = 8,16A$ ✓	$P_{ave} = I_{rms}^2 R$ ✓ $100 \checkmark = \frac{I_{max}}{\sqrt{2}} \checkmark (3) \checkmark$ $I_{max} = 8,16A \checkmark$

(5)  
 [8]

**QUESTION 11 / VRAAG 11**

- 11.1 **Marking criteria/Nasienkriteria**  
 If any one of the underlined key words/phrases in the **correct context** is omitted, deduct 1 mark. /Indien enige van die onderstreepte sleutelwoorde/frases in die **korrekte konteks** uitgelaat is, trek 1 punt af.

The minimum energy that an electron in the metal needs to be emitted from the metal surface. ✓✓

*Die minimum energie benodig om 'n elektron uit die oppervlak van 'n metaal vry te stel.*

(2)

- 11.2 Light source A – higher frequency than  $f_0$  ✓  
**OR** Light source B – lower frequency than  $f_0$

Ligbron A – hoër frekwensie as  $f_0$   
**OF** Ligbron B – laer frekwensie as  $f_0$

Wavelength  $\propto \frac{1}{f}$  ✓

Golflengte  $\propto \frac{1}{f}$



(2)

11.3.1  $W_0 = \frac{hc}{\lambda_0} \checkmark$   
 $= \frac{(6,63 \times 10^{-34})(3 \times 10^8)}{570 \times 10^{-9}} \checkmark$   
 $= 3,489 \times 10^{-19} \text{ J} \checkmark$  (3)

11.3.2 **POSITIVE MARKING FROM 11.3.1**  
 $E = W_0 + E_{k(\max)} \checkmark$   
 $\frac{hc}{\lambda} = W_0 + \frac{1}{2}mv^2$   
 $\frac{(6,63 \times 10^{-34})(3 \times 10^8)}{480 \times 10^{-9}} \checkmark = (3,489 \times 10^{-19}) \checkmark + \frac{1}{2}(9,11 \times 10^{-31})v^2 \checkmark$   
 $v = 3,79 \times 10^5 \text{ m} \cdot \text{s}^{-1} \checkmark$  (5)

11.4 Green/Groen  $\checkmark$  (1)  
**[13]**

**TOTAL/TOTAAL: 150**





# education

DEPARTMENT: EDUCATION  
MPUMALANGA PROVINCE

## ERRATA PHYISCAL SCIENCES 2023 GRADE 12 TRIAL PAPER 1

Question	Correction
1.5	Answer is A
5.5	Q5.5 should not be marked; statement was in complete.

**BASED ON Q5.5 ABOVE THE TOTAL OF THE PAPER IS NOW 145 MARKS**

