



KWAZULU-NATAL PROVINCE

**EDUCATION
REPUBLIC OF SOUTH AFRICA**

**NATIONAL
SENIOR CERTIFICATE**

GRADE 12

PHYSICAL SCIENCES

COMMON TEST

MARCH 2023

MARKS : 100

TIME : 2 Hours

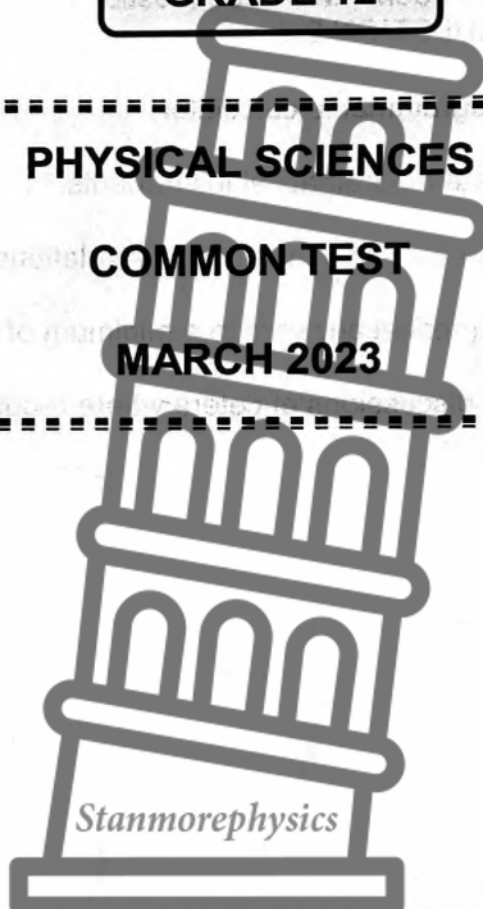

This question paper consists of 10 pages and 3 data sheets.

INSTRUCTIONS AND INFORMATION

1. Write your NAME in the appropriate spaces on the ANSWER BOOK.
2. This question paper consists of SEVEN questions. Answer ALL the questions in the ANSWER BOOK.
3. Start EACH question on a NEW page in the ANSWER BOOK.
4. Number the answers correctly according to the numbering system used in this question paper.
5. Leave ONE line between two subquestions, for example between QUESTION 2.1 and QUESTION 2.2.
6. You may use a non-programmable calculator.
7. You may use appropriate mathematical instruments.
8. Show ALL formulae and substitutions in ALL calculations.
9. Round off your final numerical answers to a minimum of TWO decimal places.
10. Give brief motivations, discussions et cetera where required.
11. You are advised to use the attached DATA SHEETS.
12. Write neatly and legibly.



QUESTION 1: MULTIPLE-CHOICE QUESTIONS

Various options are provided as possible answers to the following questions. Choose the answer and write only the letter (A-D) next to the question number (1.1-1.10) in the ANSWER BOOK, for example 1.11 D.

1.1 A body slides along a frictionless horizontal surface at **CONSTANT VELOCITY**. For which **ONE** of the following pairs are the magnitudes of both physical quantities **ZERO**?

A Displacement and momentum.

B Acceleration and momentum.

C Displacement and net force.

D Acceleration and net force.

(2)

1.2 A satellite orbits the Earth at a point X, where the gravitational force is a quarter ($\frac{1}{4}$) of the gravitational force it experiences on the surface of the Earth.

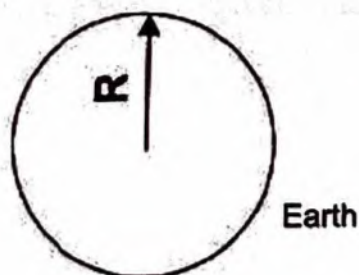
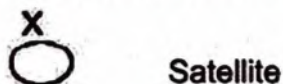

If the radius of the Earth is R , then the height of the satellite **ABOVE THE SURFACE** of the Earth will be...

A $4R$

B $2R$

C R

D $\frac{1}{2}R$

(2)



- 1.3 A girl standing in a lift observes a 10N mass piece suspended from a spring balance that is fixed to the roof of the lift. She sees that the reading on the spring balance is GREATER than 10N for a short time interval. During this time interval the lift is....
- A not moving.
- B moving at constant velocity.
- C accelerating upwards.
- D accelerating downwards. (2)
- 1.4 A ball of mass m hits a wall at a speed of v and rebounds in a straight line in the opposite direction with the same speed.
- The magnitude of the change in momentum of the ball will be...
- A 0
- B $2mv$
- C $\frac{1}{2}mv$
- D mv (2)
- 1.5 A ball is thrown vertically upwards. Which ONE of the following physical quantities has a NON-ZERO value at the instant the ball changes direction?
- A Acceleration
- B Kinetic energy
- C Momentum
- D Velocity (2)
- 1.6 The molecular formula of an organic compound is $C_4H_{10}O$. Which ONE of the following is the FUNCTIONAL GROUP of the organic compound?
- A Formyl group
- B Hydroxyl group
- C Carboxyl group
- D Carbonyl group (2)



- 1.7 A FUNCTIONAL ISOMER of ethyl propanoate is . . .
- A C_4H_9CHO .
- B $C_5H_{11}COOH$.
- C C_4H_9COOH .
- D $CH_3(CH_2)_3CHO$. (2)

- 1.8 Which ONE of the following is the EMPIRICAL FORMULA of 2 – methylpentane?
- A C_3H_7
- B C_6H_{14}
- C C_6H_{12}
- D C_3H_6 (2)

- 1.9 Which ONE of the following represents a product of the thermal cracking of butane?
- A C_2H_2
- B C_2H_4
- C C_4H_6
- D C_4H_{10} (2)

- 1.10 Consider the structural formula of an organic compound given below:

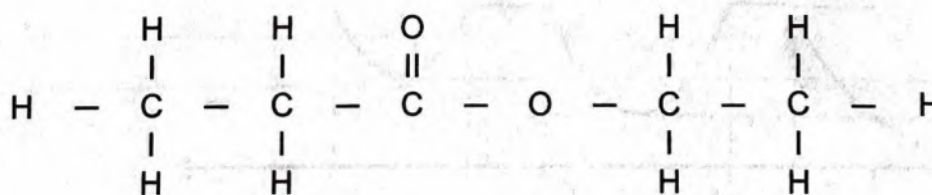

This compound is the product of the reaction between . . .

- A ethanol and propanoic acid.
- B propanol and propanoic acid.
- C ethanol and ethanoic acid.
- D propanol and ethanoic acid. (2)



[20]

QUESTION 2 (Start on a new page.)

A force of magnitude F is applied at an angle θ with the horizontal to a box of mass 60 kg placed on the floor. With force F applied, the magnitude of the maximum static frictional force between the floor and the box is 140 N . The coefficient of static friction between the box and the floor is $0,3$.

The applied force does not cause the box to lift off the floor.

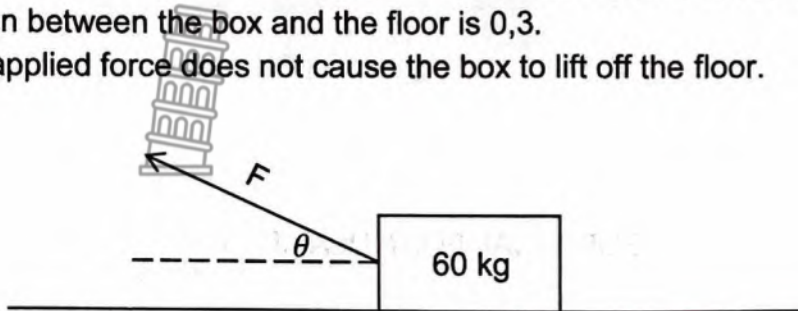

- 2.1 Define *normal force*. (2)
- 2.2 Draw the free body diagram showing all forces acting on the box. (4)
- 2.3 Calculate the magnitude of the normal force when the static frictional force is at its maximum. (3)
- 2.4 Determine the angle θ . (4)
- [13]**

QUESTION 3 (Start on a new page.)

A ball of mass $0,5 \text{ kg}$ is projected vertically downwards from a height of $1,8 \text{ m}$ with an initial velocity of $2 \text{ m}\cdot\text{s}^{-1}$. The ball hits the ground and bounces two times.

The position – time graph for the motion of the ball from the instant it is projected until it hits the ground after the second bounce is shown below. Ignore the effects of friction.

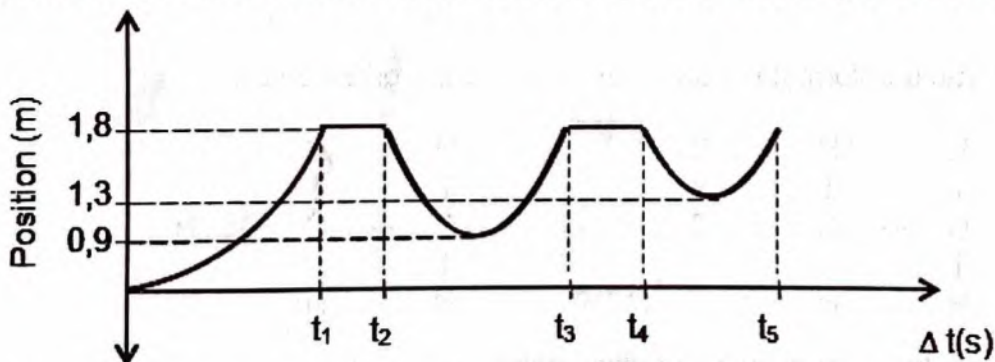

- 3.1 Write down the maximum vertical height reached by the ball after the **SECOND** bounce? (1)
- 3.2 The ball strikes the ground with a speed of $6,27 \text{ m}\cdot\text{s}^{-1}$ and is in contact with the ground for $0,2 \text{ s}$ during the first bounce.
- 3.2.1 Calculate the time t_1 as indicated on the graph. (4)
- 3.2.2 Determine the velocity with which the ball leaves the ground after the first bounce. (4)
- 3.2.3 Calculate the magnitude of the force exerted by the ground on the ball during the first bounce. (4)



- 3.3 Draw a velocity – time graph for the motion of the ball from the time that it is projected to the time it rebounds to a height of 0.9 m.

Clearly show the following on your graph:

- The time when the ball hits the ground
- The velocity of the ball when it hits the ground
- The velocity of the ball when it rebounds off the ground.

(3)
[16]

QUESTION 4 (Start on a new page.)

Two balls, A and B, of mass 250 g and 300 g respectively collide head-on. Before the collision, ball A was moving at a velocity of $4 \text{ m}\cdot\text{s}^{-1}$ to the right and ball B at $6 \text{ m}\cdot\text{s}^{-1}$ to the left. After the collision ball A moved to the left with a velocity of $2 \text{ m}\cdot\text{s}^{-1}$.

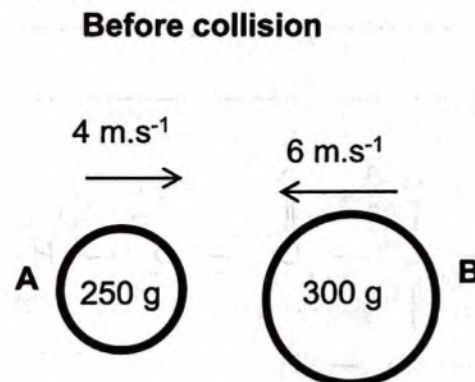

- 4.1 Explain what is meant by an *isolated system* in Physics. (2)
- 4.2 Calculate the velocity of ball B immediately after the collision. (4)
- 4.3 Is the collision between the ball A and ball B ELASTIC OR INELASTIC? Show how you arrived at the answer by means of a calculation. (5)

[11]



- 5.2 Compound B represents a TERTIARY alcohol. Write down the structural formula of compound B. (2)
- 5.3 Compound D has CHAIN and POSITIONAL isomers.
- 5.3.1 Define *positional isomer*. (2)
- 5.3.2 Write down the IUPAC NAME of the POSITIONAL isomer of compound D. (1)
- 5.3.3 Write down the structural formula of a CHAIN isomer of compound D. (2)
- 5.4 Is compound C saturated or unsaturated? Give a reason for the answer. (2)
- 5.5 Compound F undergoes complete combustion. Write a balanced equation using MOLECULAR FORMULAE to represent the reaction that takes place. (3)
- [18]**

QUESTION 6 (Start on a new page.)

The table below shows the results obtained during a practical investigation. Two experiments were conducted to determine the BOILING POINTS of compounds under the same conditions.

Experiment	Compound	Molecular Mass (g.mol ⁻¹)	Boiling Point (°C)
1	A CH ₃ COOH	60,5	11,8
	B CH ₃ (CH ₂) ₂ COOH	88,1	163
2	C CH ₃ CH ₂ CH ₂ OH	60,1	97
	D CH ₃ (CH ₂) ₃ CH ₂ OH	88,1	137

- 6.1 Define *boiling point*. (2)
- 6.2 Apart from the conditions for determining boiling points, state the controlled variable for experiment 1. (1)
- 6.3 Write down the general conclusion for this investigation. (2)
- 6.4 Which compound will have the highest vapour pressure? (1)
- 6.5 The boiling points of compounds B and D are compared.
- 6.5.1 Write down the independent variable for this comparison. (1)
- 6.5.2 Fully explain the difference in the boiling points of the two compounds. (3)
- [10]**

QUESTION 7 (Start on a new page.)

In the flow diagram below I, II and III represent organic reactions. P and Q are different organic compounds. Q is the major organic product.

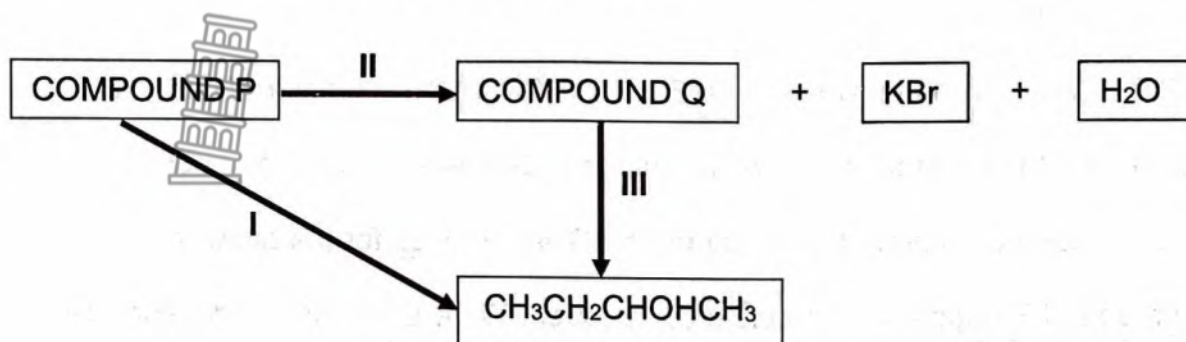

- 7.1 Name the TYPE of substitution reaction represented by reaction I. (1)
- 7.2 Write down the STRUCTURAL formula for compound Q. (2)
- 7.3 Name the inorganic reagent used in reaction III (1)
- 7.4 Write down the type of reaction represented by reaction III (1)
- 7.5 The same INORGANIC reagent is used in reactions I and II.
Write down
- 7.5.1 The NAME or FORMULA of the inorganic reagent used. (1)
- 7.5.2 ONE difference between the inorganic reagent used in reactions I and II. (2)
- 7.6 Write down the IUPAC name of:
- 7.6.1 Compound P (2)
- 7.6.2 The organic product of reaction III (2)

TOTAL MARKS: [12]
[100]



DATA FOR PHYSICAL SCIENCES (PHYSICS) GRADE 12**GEGEWENS VIR FISIESTE WETENSAPPE (FISIKA) GRAAD 12****TABLE 1: PHYSICAL CONSTANTS/TABEL 1: FISIESTE KONSTANTES**

NAME/NAAM	SYMBOL/SIMBOOL	VALUE/WAARDE
Acceleration due to gravity <i>Swaartekragversnelling</i>	g	9,8 m·s ⁻²
Universal gravitational constant	G	6,67 x 10 ⁻¹¹ N·m ² ·kg ⁻²

MOTION/BEWEGING

$v_f = v_i + a \Delta t$	$\Delta x = v_i \Delta t + \frac{1}{2} a \Delta t^2$ or/of $\Delta y = v_i \Delta t + \frac{1}{2} a \Delta t^2$
$v_f^2 = v_i^2 + 2a \Delta x$ or/of $v_f^2 = v_i^2 + 2a \Delta y$	$\Delta x = \left(\frac{v_f + v_i}{2} \right) \Delta t$ or/of $\Delta y = \left(\frac{v_f + v_i}{2} \right) \Delta t$
$K = E_k = \frac{1}{2} m v^2$	

FORCE/KRAG

$F_{net} = ma$	$p = mv$
$F_{net} \Delta t = \Delta p = m v_f - m v_i$	$F_g = mg$
$F = \frac{G m_1 m_2}{r^2}$	
$f_s^{max} = \mu_s N$	$f_k = \mu_k N$



**DATA FOR PHYSICAL SCIENCES GRADE 12
CHEMISTRY**

TABLE 1: PHYSICAL CONSTANTS:

NAME/NAAM	SYMBOL/SIMBOOL	VALUE/WAARDE
Standard pressure <i>Standaarddruk</i>	p^θ	$1,013 \times 10^5 \text{ Pa}$
Molar gas volume at STP <i>Molêre gasvolume by STD</i>	V_m	$22,4 \text{ dm}^3 \cdot \text{mol}^{-1}$
Standard temperature <i>Standaardtemperatuur</i>	T^θ	273 K
Charge on electron <i>Lading op electron</i>	E	$-1,6 \times 10^{-19} \text{ C}$
Avogadro's constant <i>Avogadro-konstante</i>	N_A	$6,02 \times 10^{23} \text{ mol}^{-1}$

TABLE 2: FORMULAE

$n = \frac{m}{M}$	$n = \frac{N}{N_A}$
$c = \frac{n}{V}$ or/of $c = \frac{m}{MV}$	$n = \frac{V}{V_m}$
$\frac{c_a V_a}{c_b V_b} = \frac{n_a}{n_b}$	$\text{pH} = -\log[\text{H}_3\text{O}^+]$
$K_w = [\text{H}_3\text{O}^+][\text{OH}^-] = 1 \times 10^{-14} \text{ at/by } 298 \text{ K}$	



TABLE 3: THE PERIODIC TABLE OF ELEMENTS

Atomic number

KEY

Electronegativity →

↓
 29
Cu
 63,5
 ↑

← Symbol

Approximate relative atomic mass

1 (I)	2 (II)	3	4	5	6	7	8	9	10	11	12	13 (III)	14 (IV)	15 (V)	16 (VI)	17 (VII)	18 (VIII)																												
1 H 1																	2 He 4																												
3 Li 7	4 Be 9																	10 Ne 20																											
11 Na 23	12 Mg 24																	18 Ar 40																											
19 K 39	20 Ca 40	21 Sc 45	22 Ti 48	23 V 51	24 Cr 52	25 Mn 55	26 Fe 56	27 Co 59	28 Ni 59	29 Cu 63,5	30 Zn 65	31 Ga 70	32 Ge 73	33 As 75	34 Se 79	35 Br 80	36 Kr 84																												
37 Rb 86	38 Sr 88	39 Y 89	40 Zr 91	41 Nb 92	42 Mo 96	43 Tc	44 Ru 101	45 Rh 103	46 Pd 106	47 Ag 108	48 Cd 112	49 In 115	50 Sn 119	51 Sb 122	52 Te 128	53 I 127	54 Xe 131																												
55 Cs 133	56 Ba 137	57 La 139	72 Hf 179	73 Ta 181	74 W 184	75 Re 186	76 Os 190	77 Ir 192	78 Pt 195	79 Au 197	80 Hg 201	81 Tl 204	82 Pb 207	83 Bi 209	84 Po	85 At	86 Rn																												
87 Fr	88 Ra 226	89 Ac																																											
		<table border="1" style="width: 100%; border-collapse: collapse; text-align: center;"> <tr> <td>58 Ce 140</td> <td>59 Pr 141</td> <td>60 Nd 144</td> <td>61 Pm</td> <td>62 Sm 150</td> <td>63 Eu 152</td> <td>64 Gd 157</td> <td>65 Tb 159</td> <td>66 Dy 163</td> <td>67 Ho 165</td> <td>68 Er 167</td> <td>69 Tm 169</td> <td>70 Yb 173</td> <td>71 Lu 175</td> </tr> <tr> <td>90 Th 232</td> <td>91 Pa</td> <td>92 U 238</td> <td>93 Np</td> <td>94 Pu</td> <td>95 Am</td> <td>96 Cm</td> <td>97 Bk</td> <td>98 Cf</td> <td>99 Es</td> <td>100 Fm</td> <td>101 Md</td> <td>102 No</td> <td>103 Lr</td> </tr> </table>																58 Ce 140	59 Pr 141	60 Nd 144	61 Pm	62 Sm 150	63 Eu 152	64 Gd 157	65 Tb 159	66 Dy 163	67 Ho 165	68 Er 167	69 Tm 169	70 Yb 173	71 Lu 175	90 Th 232	91 Pa	92 U 238	93 Np	94 Pu	95 Am	96 Cm	97 Bk	98 Cf	99 Es	100 Fm	101 Md	102 No	103 Lr
58 Ce 140	59 Pr 141	60 Nd 144	61 Pm	62 Sm 150	63 Eu 152	64 Gd 157	65 Tb 159	66 Dy 163	67 Ho 165	68 Er 167	69 Tm 169	70 Yb 173	71 Lu 175																																
90 Th 232	91 Pa	92 U 238	93 Np	94 Pu	95 Am	96 Cm	97 Bk	98 Cf	99 Es	100 Fm	101 Md	102 No	103 Lr																																



education

Department:
Education
PROVINCE OF KWAZULU-NATAL

**NATIONAL
SENIOR CERTIFICATE**

GRADE 12

**PHYSICAL SCIENCES
COMMON TEST
MARCH 2023
MARKING GUIDELINE**

MARKS : 100

Stanmorephysics

This Marking Guideline consists of 10 pages.

QUESTION 1: MULTIPLE-CHOICE QUESTIONS

1.1 D✓✓

1.2 C✓✓

1.3 C✓✓

1.4 B✓✓

1.5 A✓✓

1.6 B✓✓

1.7 C✓✓

1.8 A✓✓

1.9 B✓✓

1.10 A✓✓



[20]

QUESTION 2 (Start on a new page.)

2.1 **Normal force** is the force or component of a force which a surface exerts on an object with which it is in contact, and which is perpendicular to the surface. ✓✓ (2)

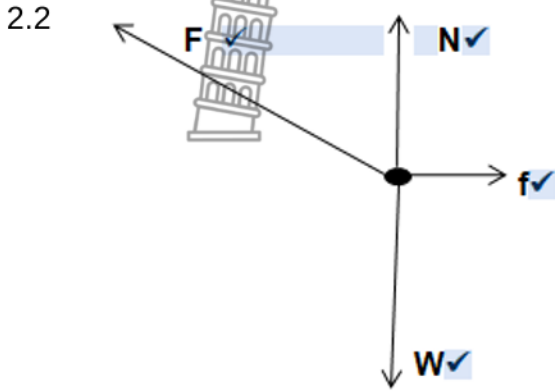

Accept the following symbols	
N	Normal Force/Normal/ F_N
f	Static friction/ f_s
W	Weight/ F_W /Gravitational force/ f_g
F	Force applied/ F_A

Notes

- Mark is awarded for label and arrow.
- Do not penalize for length of the arrows.
- Deduct 1 mark or any additional force.
- If force(s) do not make contact with body/dot: *Max: 3/4*
- If arrows missing but labels are there: *Max: 3/4*

2.3 $f_s^{\max} = \mu_s N$ ✓
 $140 = 0,3N$ ✓
 $N = 466,67N$ ✓ (3)

2.4 **POSITIVE MARKING FROM 2.3**

$$F_x = f_s^{\max} = 140N \checkmark$$

$$N = F_g - F_y \checkmark$$

$$466,67 = (60)(9,8) - F_y \checkmark$$

$$F_y = 121,33N$$

$$\tan \theta = \frac{F_y}{F_x}$$

$$\tan \theta = \frac{121,33}{140} \checkmark$$

$$\theta = 40.91^\circ \checkmark$$

(4)
[13]

QUESTION 3 (Start on a new page.)

3.1 0,5 m ✓

(1)

3.2.1 **OPTION 1/OPSIE 1**

Upwards positive

$$v_f = v_i + a\Delta t \checkmark$$

$$\frac{-6,27 \checkmark}{\Delta t} = -2 + (-9,8)\Delta t \checkmark$$

$$\Delta t = 0,44 \text{ s } \checkmark$$

Downwards positive

$$v_f = v_i + a\Delta t \checkmark$$

$$\frac{6,27 \checkmark}{\Delta t} = 2 + (9,8)\Delta t \checkmark$$

$$\Delta t = 0,44 \text{ s } \checkmark$$

OPTION 2/OPSIE 2

Upwards positive

$$\Delta y = v_i\Delta t + \frac{1}{2} a\Delta t^2 \checkmark$$

$$-1,8 \checkmark = (-2)\Delta t + \frac{1}{2} (-9,8)\Delta t^2 \checkmark$$

$$\Delta t = \frac{-b \pm \sqrt{b^2 - 4ac}}{2a}$$

$$\Delta t = \frac{-2 \pm \sqrt{(2)^2 - 4(4,9)(-1,8)}}{2(4,9)}$$

$$= 0,44 \text{ s } \checkmark$$

Downwards positive

$$\Delta y = v_i\Delta t + \frac{1}{2} a\Delta t^2 \checkmark$$

$$1,8 \checkmark = (2)\Delta t + \frac{1}{2} (9,8)\Delta t^2 \checkmark$$

$$\Delta t = \frac{-b \pm \sqrt{b^2 - 4ac}}{2a}$$

$$\Delta t = \frac{-2 \pm \sqrt{(-2)^2 - 4(4,9)(-1,8)}}{2(4,9)}$$

$$= 0,44 \text{ s } \checkmark$$

(4)

OPTION 3

$$\Delta y = \frac{(v_i + v_f)}{2} \Delta t \checkmark$$

$$1,8 \checkmark = \frac{(2 + 6,27)}{2} \Delta t \checkmark$$

$$\Delta t = 0,44 \text{ s} \checkmark$$



(4)

3.2.2 Upwards positive:

$$v_f^2 = v_i^2 + 2a\Delta y \checkmark$$

$$0^2 = v_i^2 + 2(-9,8)(0,9) \checkmark$$

$$v_i = 4,2 \text{ m}\cdot\text{s}^{-1} \checkmark \text{ upwards} \checkmark$$

Downwards positive:

$$v_f^2 = v_i^2 + 2a\Delta y \checkmark$$

$$0^2 = v_i^2 + 2(9,8)(0,9) \checkmark$$

$$v_i = 4,2 \text{ m}\cdot\text{s}^{-1} \checkmark \text{ upwards} \checkmark$$

(4)

3.2.3 Upwards positive:

$$F_{\text{net}} \Delta t = m\Delta v$$

$$F_{\text{net}} (0,2) = (0,5)[(4,2 - (-6,27))] \checkmark$$

$$F_{\text{net}} = 26,175 \text{ N}$$

$$F_{\text{net}} = F - F_g$$

$$26,1755 = F - (0,5)(9,8) \checkmark$$

$$F = 31,075 \text{ N} \checkmark$$

✓ for either equation

Downwards positive:

$$F_{\text{net}} \Delta t = m\Delta v \checkmark$$

$$F_{\text{net}} (0,2) = (0,5)[(-4,2 - (6,27))] \checkmark$$

$$F_{\text{net}} = -26,175 \text{ N}$$

$$F_{\text{net}} = 26,175 \text{ N}$$

$$F_{\text{net}} = F_g - F$$

$$-26,1755 = (0,5)(9,8) - F \checkmark$$

$$F = 31,075 \text{ N} \checkmark$$

✓ for either equation

(4)

3.5 Upwards positive:

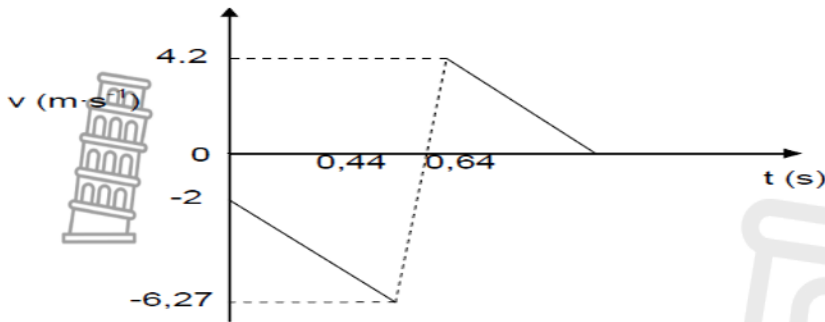

Downwards positive:

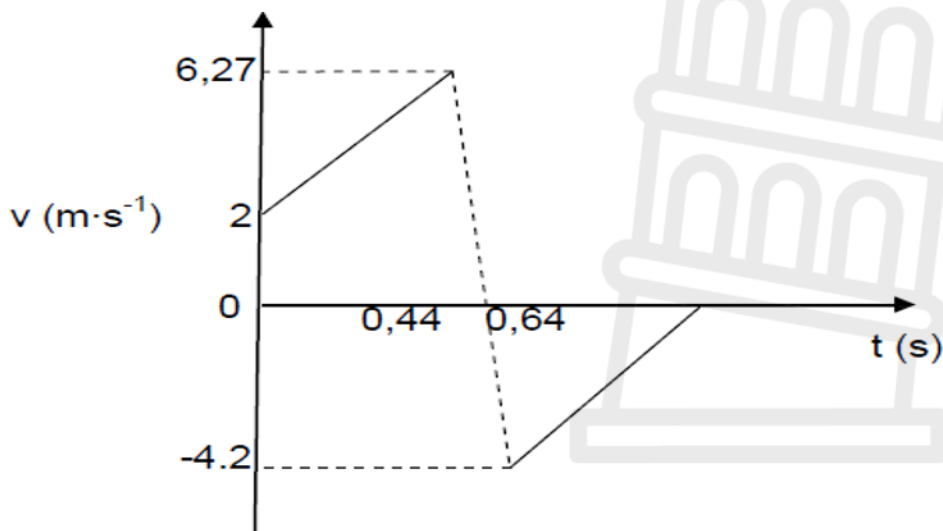

Criteria for graph	Marks
2 straight discontinuous parallel lines, one above and one below the time axis	✓
First part of the graph starts at $v = 2 \text{ m}\cdot\text{s}^{-1}$ at $t = 0 \text{ s}$ and extends until $v = 6,27 \text{ m}\cdot\text{s}^{-1}$ at $t = 0,44 \text{ s}$.	✓
Second part of graph starts at $v = 4,2 \text{ m}\cdot\text{s}^{-1}$ at $t = 0,64 \text{ s}$ until $v = 0 \text{ m}\cdot\text{s}^{-1}$.	✓

(3)
 [16]

QUESTION 4 (Start on a new page.)

4.1 A system on which the net external force is zero. ✓✓ (2)

4.2 **Right as Positive:**

$$\left. \begin{aligned} \Sigma p_i &= \Sigma p_f \\ \Delta p_A &= -\Delta p_B \\ m_A v_{iA} + m_B v_{iB} &= m_A v_{fA} + m_B v_{fB} \end{aligned} \right\} \begin{array}{l} \text{Any} \\ \text{one} \end{array} \checkmark$$

$$(0,25)(4) + (0,3)(-6) = (0,25)(-2) + (0,3)(v_{f2}) \checkmark \checkmark$$

$$v_{f2} = -1 \text{ m}\cdot\text{s}^{-1}$$

$$v_{f2} = 1 \text{ m}\cdot\text{s}^{-1} \text{ to the left} \checkmark$$

Left as Positive:

$$\left. \begin{aligned} \Sigma p_i &= \Sigma p_f \\ \Delta p_A &= -\Delta p_B \\ m_A v_{iA} + m_B v_{iB} &= m_A v_{fA} + m_B v_{fB} \end{aligned} \right\} \begin{array}{l} \text{Any} \\ \text{one} \end{array} \checkmark$$

$$(0,25)(-4) + (0,3)(6) = (0,25)(2) + (0,3)(v_{f2}) \checkmark \checkmark$$

$$v_{f2} = 1 \text{ m}\cdot\text{s}^{-1}$$

$$v_{f2} = 1 \text{ m}\cdot\text{s}^{-1} \text{ to the left} \checkmark$$

(4)

4.3

$$\Sigma E_{k(\text{before})} = \frac{1}{2} m_A v_{iA}^2 + \frac{1}{2} m_B v_{iB}^2 \checkmark$$

$$= \frac{1}{2} (0,25)(4)^2 + \frac{1}{2} (0,3)(-6)^2 \checkmark$$

$$= 7,4 \text{ J}$$

$$\Sigma E_{k(\text{after})} = \frac{1}{2} m_A v_{fA}^2 + \frac{1}{2} m_B v_{fB}^2$$

$$= \frac{1}{2} (0,25)(-2)^2 + \frac{1}{2} (0,3)(-1)^2 \checkmark$$

$$= 0,65 \text{ J}$$

$$\Sigma E_{k(\text{before})} \neq \Sigma E_{k(\text{after})} \checkmark$$

∴ INELASTIC ✓

NOTE: If starts with $\Sigma E_{k(\text{before})} = \Sigma E_{k(\text{after})}$ maximum 2/5

(5)
[11]

QUESTION 5

5.1.1 4,5 – dimethyl ✓ hex – 2 – ✓ ene ✓

Marking criteria:

- Identify as alkene: ✓
- Hex – 2 -: ✓
- All the substituents correct and correctly numbered: ✓

(3)

5.1.2 C ✓

(1)

5.1.3 carboxyl ✓

(1)

5.1.4 C_nH_{2n} ✓

(1)

5.2

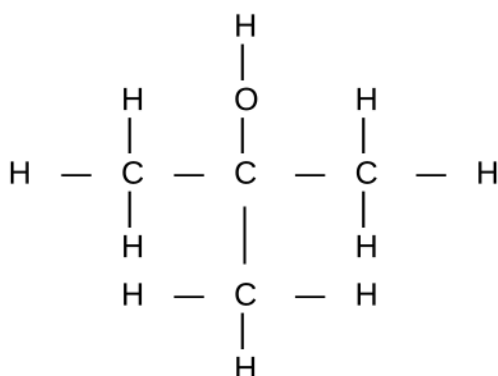

Marking criteria:

- Correct functional group: $\frac{1}{2}$
- Whole structure correct: $\frac{2}{2}$

(2)

5.3.1 Organic molecules with the same molecular formula but different positions of the side chains/substituents/functional groups on the parent chain ✓✓

(2)

5.3.2 but – 1 – ene ✓

(1)

5.3.3

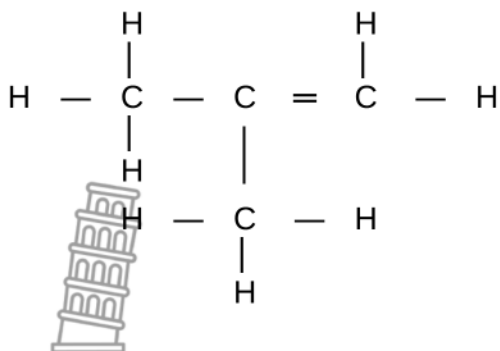

Marking criteria:

- 3 carbons in parent chain with the double bond ✓
- Methyl group as a substituent ✓

(2)

5.4 Unsaturated ✓

There multiple bonds between C atoms in the hydrocarbon chain/triple bond between C atoms in the hydrocarbon chain. ✓

(2)

5.5 $2 C_6H_{14} + 19 O_2 \rightarrow 12 CO_2 + 14 H_2O$
 Reactants ✓ Products ✓ Balancing ✓

(3)

[18]

QUESTION 6

6.1 The temperature at which the vapour pressure equals atmospheric (external) pressure. ✓✓ (2 or 0)

(2)

6.2 Compounds have the same functional group/belong to the same homologous series ✓

(1)

6.3 As the length of the carbon chain/molecular mass increases the boiling point increases for the same functional group/homologous series ✓✓

(2)

6.4 A ✓

(1)

6.5.1 Type of functional group/organic compound/homologous series. ✓

(1)

- 6.5.2
- B has 2 sites for hydrogen bonding ✓ and
 - therefore has stronger intermolecular forces ✓
 - That require more energy to overcome. ✓

OR

- D has only 1 site for hydrogen bonding ✓ and
- therefore has weaker intermolecular forces ✓
- That require less energy to overcome. ✓

(3)

[10]

QUESTION 7

7.1 hydrolysis✓ (1)

7.2.

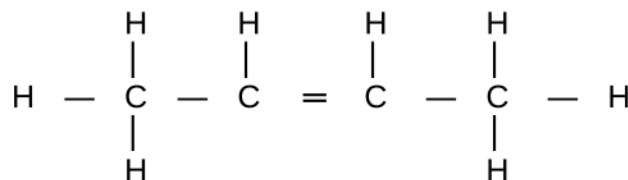

Double bond between the second and third carbon atoms✓
Whole structure correct✓

(2)

7.3 Water(H₂O)/sulphuric acidH₂SO₄/phosphoric acidH₃PO₄/hydrogen chloride(HCl) ✓ (1)

7.4 Addition/hydration ✓ (1)

7.5.1 Potassium hydroxide/KOH ✓ (1)

7.5.2 KOH in reaction I is dilute. ✓
KOH in reaction II is concentrated. ✓ (2)

7.6.1 2 - bromo✓butane✓ (2)

7.6.2 Butan✓ - 2 - ol ✓ (2)

[12]

TOTAL MARKS: 100